

Scroll Down to see the Technical Drawings

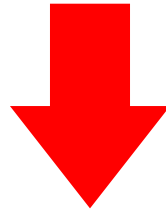

TOP CHORD 3X2 SPF CAN. 1650F-1.5E
 BOTTOM CHORD 3X2 SPF CAN. 1650F-1.5E
 LUMBER SHEAR ALLOWABLES ARE PER NDS-1997

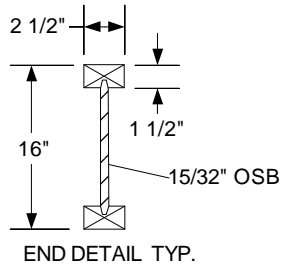

| 16" SPACEJOIST TE MAXIMUM SPANS | | | | | |
|---------------------------------|------------------|----------|------------|----------|----------|
| LOADING, PSF | DEFLECTION RATIO | SPACING | | | |
| | | 24" o.c. | 19.2" o.c. | 16" o.c. | 12" o.c. |
| 40-10-5 | L/480 | 21'- 9" | 24'- 2" | 25'- 8" | 28'- 0" |
| | L/360 | 21'- 9" | 24'- 5" | 26'- 8" | 28'- 0" |
| 40-20-5 | L/480 | 18'-3" | 22'-0" | 24'-9" | 28'-0" |
| | L/360 | 18'-3" | 22'-0" | 24'-9" | 28'-0" |

THIS TRUSS IS TRIMMABLE
 UP TO 12" MAY BE FIELD-TRIMMED
 FROM EACH END OF THIS JOIST

SEE TX96284011-001 FOR SPACEJOIST TE
 ASSEMBLY AND GENERAL NOTES

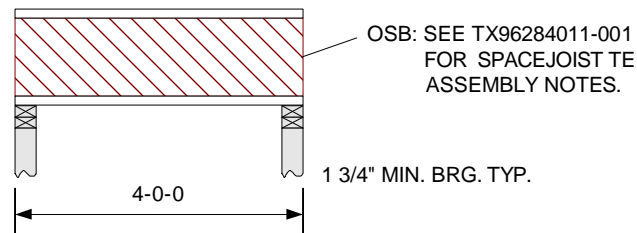

ALL WEBS ARE 20 GAUGE SPACEJOIST METAL WEBS MANUFACTURED BY TRUSWAL SYSTEMS CORPORATION.

DATE: 07-23-04
 DESIGNED BY TRUSWAL SYSTEMS



WARNING Read all notes on this sheet and give a copy of it to the Erecting Contractor.
 This design is for an individual building component, not a truss system. It has been based on specifications provided by the component manufacturer and has been completed in accordance with the current versions of TPI and AFPA design standards. No responsibility is assumed for dimensional accuracy. Dimensions are to be verified by the component manufacturer and/or building designer prior to fabrication. The building designer shall ascertain that the loads utilized on this design meet or exceed the loading imposed by the local building code and the particular application. This design assumes that the top chord is laterally braced by the roof or floor sheathing and that the bottom chord is laterally braced by a rigid sheathing material directly attached, unless otherwise noted. Bracing shown is for lateral support of individual component members only. This component shall not be placed in any environment that will cause the moisture content of the wood to exceed 19% and/or cause connector plate corrosion. Fabricate, handle, install, and brace this truss in accordance with the following standards: *SPACEJOIST TRUSS FABRICATION MANUAL*, by Truswal Systems; *Handling, Installing, and Bracing Metal Plate Connected Wood Trusses* (HIB-91 and HIB-91 Summary Sheet) by TPI. The Truss Plate Institute is located at 583 D'Onofrio Dr., Ste. 200, Madison, WI 53719. The American Forest and Paper Association (AFPA) is located at 1111 19th St. N.W., Ste. 800, Washington, DC 20036.

| | |
|--|--|
| Chk: Dsgnr: DL | Customer Name: SpaceJoist TE |
| TC Live 40 psf TC Dead See Span Table BC Live 0 psf BC Dead 5 psf TOTAL See Span Table | DurFacs: L= 1.00 P= 1.00 Rep Mbr Bnd: 1.15 Spacing: See Span Table Design Spec: TPI |

TOP CHORD 3X2 SPF CAN. 1650F-1.8E
 BOTTOM CHORD 3X2 SPF CAN. 1650F-1.8E
 LUMBER SHEAR ALLOWABLES ARE PER NDS-1997

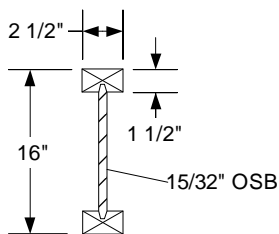

END DETAIL TYP.

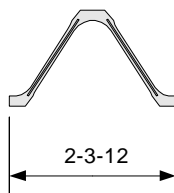

| 16" SPACEJOIST TE MAXIMUM SPANS | | | | | |
|---------------------------------|------------------|----------|------------|----------|----------|
| LOADING, PSF | DEFLECTION RATIO | SPACING | | | |
| | | 24" o.c. | 19.2" o.c. | 16" o.c. | 12" o.c. |
| 40-10-5 | L/480 | 21'- 9" | 24'- 2" | 25'- 8" | 28'- 0" |
| | L/360 | 21'- 9" | 24'- 5" | 26'- 8" | 28'- 0" |
| 40-20-5 | L/480 | 18'-3" | 22'-0" | 24'-9" | 28'-0" |
| | L/360 | 18'-3" | 22'-0" | 24'-9" | 28'-0" |

THIS TRUSS IS TRIMMABLE

UP TO 18" MAY BE FIELD TRIMMED FROM EACH END OF THIS TRUSS

SEE TX96284011-001 FOR SPACEJOIST TE ASSEMBLY AND GENERAL NOTES

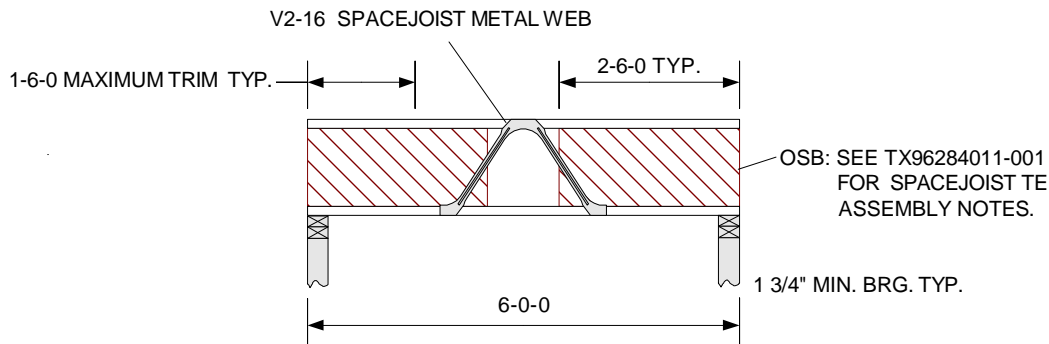

ALL WEBS ARE 20 GAUGE SPACEJOIST METAL WEBS MANUFACTURED BY TRUSWAL SYSTEMS CORPORATION.

DATE: 07-23-04

DESIGNED BY TRUSWAL SYSTEMS



WARNING Read all notes on this sheet and give a copy of it to the Erecting Contractor. This design is for an individual building component, not a truss system. It has been based on specifications provided by the component manufacturer and has been completed in accordance with the current versions of TPI and AFPA design standards. No responsibility is assumed for dimensional accuracy. Dimensions are to be verified by the component manufacturer and/or building designer prior to fabrication. The building designer shall ascertain that the loads utilized on this design meet or exceed the loading imposed by the local building code and the particular application. This design assumes that the top chord is laterally braced by the roof or floor sheathing and that the bottom chord is laterally braced by a rigid sheathing material directly attached, unless otherwise noted. Bracing shown is for lateral support of individual component members only. This component shall not be placed in any environment that will cause the moisture content of the wood to exceed 19% and/or cause connector plate corrosion. Fabricate, handle, install, and brace this truss in accordance with the following standards: SPACEJOIST TRUSS FABRICATION MANUAL, by Truswal Systems; Handling, Installing, and Bracing Metal Plate Connected Wood Trusses (HIB-91 and HIB-91 Summary Sheet) by TPI. The Truss Plate Institute is located at 583 D'Onofrio Dr., Ste. 200, Madison, WI 53719. The American Forest and Paper Association (AFPA) is located at 1111 19th St. N.W., Ste. 800, Washington, DC 20036.

| | |
|-----------|----------------|
| Chk: | |
| Dsgnr: DL | |
| TC Live | 40 psf |
| TC Dead | See Span Table |
| BC Live | 0 psf |
| BC Dead | 5 psf |
| TOTAL | See Span Table |

| | |
|----------------|-----------------|
| Customer Name: | SpaceJoist TE |
| DurFacs: | L= 1.00 P= 1.00 |
| Rep Mbr Bnd: | 1.15 |
| Spacing: | See Span Table |
| Design Spec: | TPI |

TOP CHORD 3X2 SPF CAN. 1650F-1.5E
 BOTTOM CHORD 3X2 SPF CAN. 1650F-1.5E
 LUMBER SHEAR ALLOWABLES ARE PER NDS-1997

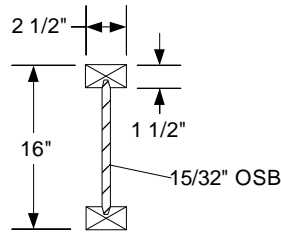

END DETAIL TYP.

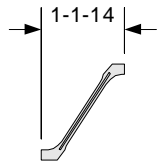

| 16" SPACEJOIST TE MAXIMUM SPANS | | | | | |
|---------------------------------|------------------|----------|------------|----------|----------|
| LOADING, PSF | DEFLECTION RATIO | SPACING | | | |
| | | 24" o.c. | 19.2" o.c. | 16" o.c. | 12" o.c. |
| 40-10-5 | L/480 | 21'- 9" | 24'- 2" | 25'- 8" | 28'- 0" |
| | L/360 | 21'- 9" | 24'- 5" | 26'- 8" | 28'- 0" |
| 40-20-5 | L/480 | 18'-3" | 22'-0" | 24'-9" | 28'-0" |
| | L/360 | 18'-3" | 22'-0" | 24'-9" | 28'-0" |

THIS TRUSS IS TRIMMABLE

UP TO 12" MAY BE FIELD TRIMMED FROM EACH END OF THIS TRUSS

SEE TX96284011-001 FOR SPACEJOIST TE ASSEMBLY AND GENERAL NOTES

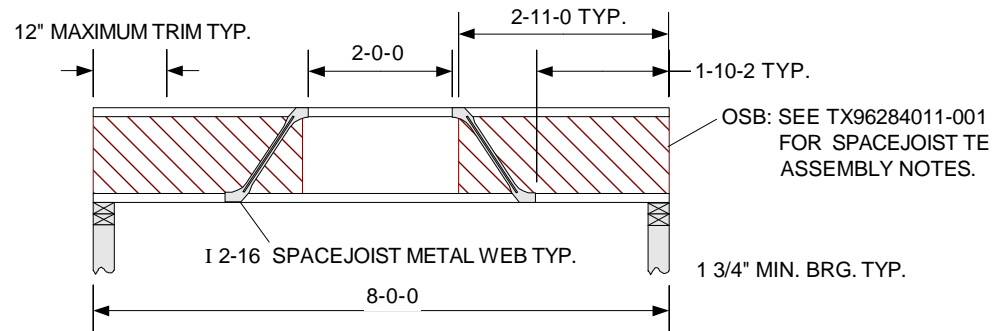

ALL WEBS ARE 20 GAUGE SPACEJOIST METAL WEBS MANUFACTURED BY TRUSWAL SYSTEMS CORPORATION.

DATE: 07-23-04
 DESIGNED BY TRUSWAL SYSTEMS



WARNING Read all notes on this sheet and give a copy of it to the Erecting Contractor. This design is for an individual building component, not a truss system. It has been based on specifications provided by the component manufacturer and has been completed in accordance with the current versions of TPI and AFPA design standards. No responsibility is assumed for dimensional accuracy. Dimensions are to be verified by the component manufacturer and/or building designer prior to fabrication. The building designer shall ascertain that the loads utilized on this design meet or exceed the loading imposed by the local building code and the particular application. This design assumes that the top chord is laterally braced by the roof or floor sheathing and that the bottom chord is laterally braced by a rigid sheathing material directly attached, unless otherwise noted. Bracing shown is for lateral support of individual component members only. This component shall not be placed in any environment that will cause the moisture content of the wood to exceed 19% and/or cause connector plate corrosion. Fabricate, handle, install, and brace this truss in accordance with the following standards: SPACEJOIST TRUSS FABRICATION MANUAL, by Truswal Systems; Handling, Installing, and Bracing Metal Plate Connected Wood Trusses (HIB-91 and HIB-91 Summary Sheet) by TPI. The Truss Plate Institute is located at 583 D'Onofrio Dr., Ste. 200, Madison, WI 53719. The American Forest and Paper Association (AFPA) is located at 1111 19th St. N.W., Ste. 800, Washington, DC 20036.

| | | | |
|-----------|----------------|--------------------------|---------------|
| Chk: | | Customer Name: | SpaceJoist TE |
| Dsgnr: DL | | | |
| TC Live | 40 psf | DurFacs: L= 1.00 P= 1.00 | |
| TC Dead | See Span Table | Rep Mbr Bnd: 1.15 | |
| BC Live | 0 psf | Spacing: See Span Table | |
| BC Dead | 5 psf | Design Spec: TPI | |
| TOTAL | See Span Table | | |

TOP CHORD 3X2 SPF CAN. 1650F-1.5E
 BOTTOM CHORD 3X2 SPF CAN. 1650F-1.5E
 LUMBER SHEAR ALLOWABLES ARE PER NDS-1997

| 16" SPACEJOIST TE MAXIMUM SPANS | | | | | |
|---------------------------------|------------------|----------|------------|----------|----------|
| LOADING, PSF | DEFLECTION RATIO | SPACING | | | |
| | | 24" o.c. | 19.2" o.c. | 16" o.c. | 12" o.c. |
| 40-10-5 | L/480 | 21'- 9" | 24'- 2" | 25'- 8" | 28'- 0" |
| | L/360 | 21'- 9" | 24'- 5" | 26'- 8" | 28'- 0" |
| 40-20-5 | L/480 | 18'- 3" | 22'- 0" | 24'- 9" | 28'- 0" |
| | L/360 | 18'- 3" | 22'- 0" | 24'- 9" | 28'- 0" |

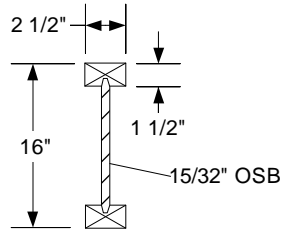

END DETAIL TYP.

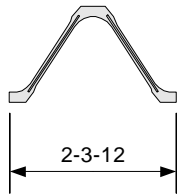

THIS TRUSS IS TRIMMABLE

UP TO 12" MAY BE FIELD TRIMMED FROM EACH END OF THIS TRUSS

SEE TX96284011-001 FOR SPACEJOIST TE ASSEMBLY AND GENERAL NOTES

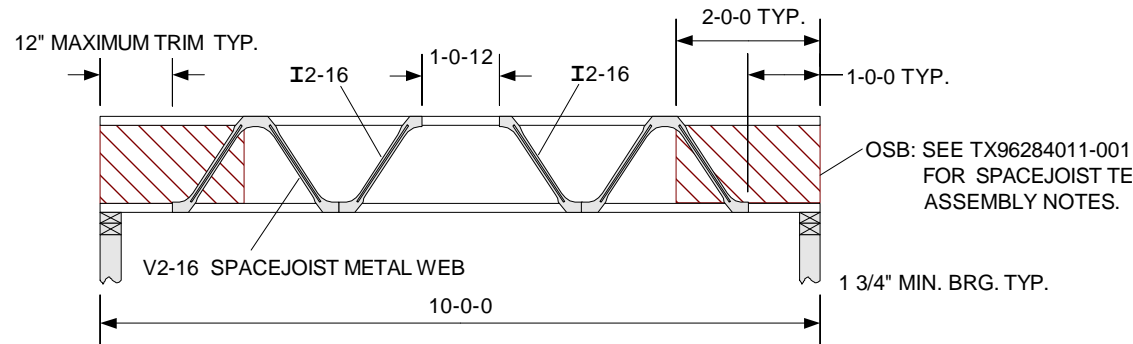

OSB: SEE TX96284011-001 FOR SPACEJOIST TE ASSEMBLY NOTES.

1 3/4" MIN. BRG. TYP.

ALL WEBS ARE 20 GAUGE SPACEJOIST METAL WEBS MANUFACTURED BY TRUSWAL SYSTEMS CORPORATION.

DATE: 07-23-04

DESIGNED BY TRUSWAL SYSTEMS



WARNING Read all notes on this sheet and give a copy of it to the Erecting Contractor. This design is for an individual building component, not a truss system. It has been based on specifications provided by the component manufacturer and has been completed in accordance with the current versions of TPI and AFPA design standards. No responsibility is assumed for dimensional accuracy. Dimensions are to be verified by the component manufacturer and/or building designer prior to fabrication. The building designer shall ascertain that the loads utilized on this design meet or exceed the loading imposed by the local building code and the particular application. This design assumes that the top chord is laterally braced by the roof or floor sheathing and that the bottom chord is laterally braced by a rigid sheathing material directly attached, unless otherwise noted. Bracing shown is for lateral support of individual component members only. This component shall not be placed in any environment that will cause the moisture content of the wood to exceed 19% and/or cause connector plate corrosion. Fabricate, handle, install, and brace this truss in accordance with the following standards: SPACEJOIST TRUSS FABRICATION MANUAL, by Truswal Systems; Handling, Installing, and Bracing Metal Plate Connected Wood Trusses (HIB-91 and HIB-91 Summary Sheet) by TPI. The Truss Plate Institute is located at 583 D'Onofrio Dr., Ste. 200, Madison, WI 53719. The American Forest and Paper Association (AFPA) is located at 1111 19th St. N.W., Ste. 800, Washington, DC 20036.

| | |
|-----------|----------------|
| Chk: | |
| Dsgnr: DL | |
| TC Live | 40 psf |
| TC Dead | See Span Table |
| BC Live | 0 psf |
| BC Dead | 5 psf |
| TOTAL | See Span Table |

| | |
|----------------|-----------------|
| Customer Name: | SpaceJoist TE |
| DurFacs: | L= 1.00 P= 1.00 |
| Rep Mbr Bnd: | 1.15 |
| Spacing: | See Span Table |
| Design Spec: | TPI |

TOP CHORD 3X2 SPF CAN. 1650F-1.5E
 BOTTOM CHORD 3X2 SPF CAN. 1650F-1.5E
 LUMBER SHEAR ALLOWABLES ARE PER NDS-1997

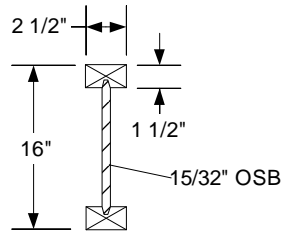

END DETAIL TYP.

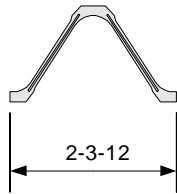

| 16" SPACEJOIST TE MAXIMUM SPANS | | | | | |
|---------------------------------|------------------|----------|------------|----------|----------|
| LOADING, PSF | DEFLECTION RATIO | SPACING | | | |
| | | 24" o.c. | 19.2" o.c. | 16" o.c. | 12" o.c. |
| 40-10-5 | L/480 | 21'- 9" | 24'- 2" | 25'- 8" | 28'- 0" |
| | L/360 | 21'- 9" | 24'- 5" | 26'- 8" | 28'- 0" |
| 40-20-5 | L/480 | 18'-3" | 22'-0" | 24'-9" | 28'-0" |
| | L/360 | 18'-3" | 22'-0" | 24'-9" | 28'-0" |

THIS TRUSS IS TRIMMABLE

UP TO 12" MAY BE FIELD TRIMMED FROM EACH END OF THIS TRUSS

SEE TX96284011-001 FOR SPACEJOIST TE ASSEMBLY AND GENERAL NOTES

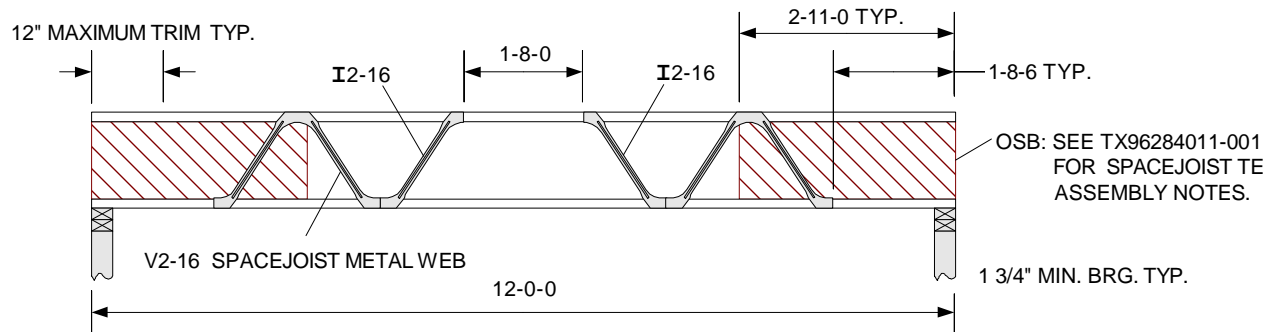

ALL WEBS ARE 20 GAUGE SPACEJOIST METAL WEBS MANUFACTURED BY TRUSWAL SYSTEMS CORPORATION.

DATE: 07-23-04

DESIGNED BY TRUSWAL SYSTEMS



WARNING Read all notes on this sheet and give a copy of it to the Erecting Contractor. This design is for an individual building component, not a truss system. It has been based on specifications provided by the component manufacturer and has been completed in accordance with the current versions of TPI and AFPA design standards. No responsibility is assumed for dimensional accuracy. Dimensions are to be verified by the component manufacturer and/or building designer prior to fabrication. The building designer shall ascertain that the loads utilized on this design meet or exceed the loading imposed by the local building code and the particular application. This design assumes that the top chord is laterally braced by the roof or floor sheathing and that the bottom chord is laterally braced by a rigid sheathing material directly attached, unless otherwise noted. Bracing shown is for lateral support of individual component members only. This component shall not be placed in any environment that will cause the moisture content of the wood to exceed 19% and/or cause connector plate corrosion. Fabricate, handle, install, and brace this truss in accordance with the following standards: *SPACEJOIST TRUSS FABRICATION MANUAL*, by Truswal Systems; *Handling, Installing, and Bracing Metal Plate Connected Wood Trusses* (HIB-91 and HIB-91 Summary Sheet) by TPI. The Truss Plate Institute is located at 583 D'Onofrio Dr., Ste. 200, Madison, WI 53719. The American Forest and Paper Association (AFPA) is located at 1111 19th St. N.W., Ste. 800, Washington, DC 20036.

| | |
|-----------|----------------|
| Chk: | |
| Dsgnr: DL | |
| TC Live | 40 psf |
| TC Dead | See Span Table |
| BC Live | 0 psf |
| BC Dead | 5 psf |
| TOTAL | See Span Table |

| | |
|----------------|-----------------|
| Customer Name: | SpaceJoist TE |
| DurFacs: | L= 1.00 P= 1.00 |
| Rep Mbr Bnd: | 1.15 |
| Spacing: | See Span Table |
| Design Spec: | TPI |

TOP CHORD 3X2 SPF CAN. 2100F-1.8E
 BOTTOM CHORD 3X2 SPF CAN. 2100F-1.8E
 LUMBER SHEAR ALLOWABLES ARE PER NDS-1997

| 16" SPACEJOIST TE MAXIMUM SPANS | | | | | |
|---------------------------------|------------------|----------|------------|----------|----------|
| LOADING, PSF | DEFLECTION RATIO | SPACING | | | |
| | | 24" o.c. | 19.2" o.c. | 16" o.c. | 12" o.c. |
| 40-10-5 | L/480 | 21'- 9" | 24'- 2" | 25'- 8" | 28'- 0" |
| | L/360 | 21'- 9" | 24'- 5" | 26'- 8" | 28'- 0" |
| 40-20-5 | L/480 | 18'- 3" | 22'- 0" | 24'- 9" | 28'- 0" |
| | L/360 | 18'- 3" | 22'- 0" | 24'- 9" | 28'- 0" |

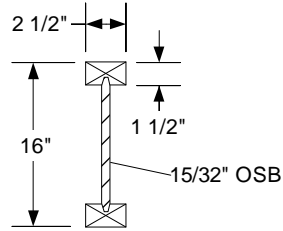

END DETAIL TYP.

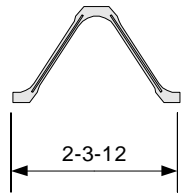

THIS TRUSS IS TRIMMABLE
 UP TO 12" MAY BE FIELD TRIMMED
 FROM EACH END OF THIS TRUSS

SEE TX96284011-001 FOR SPACEJOIST TE
 ASSEMBLY AND GENERAL NOTES

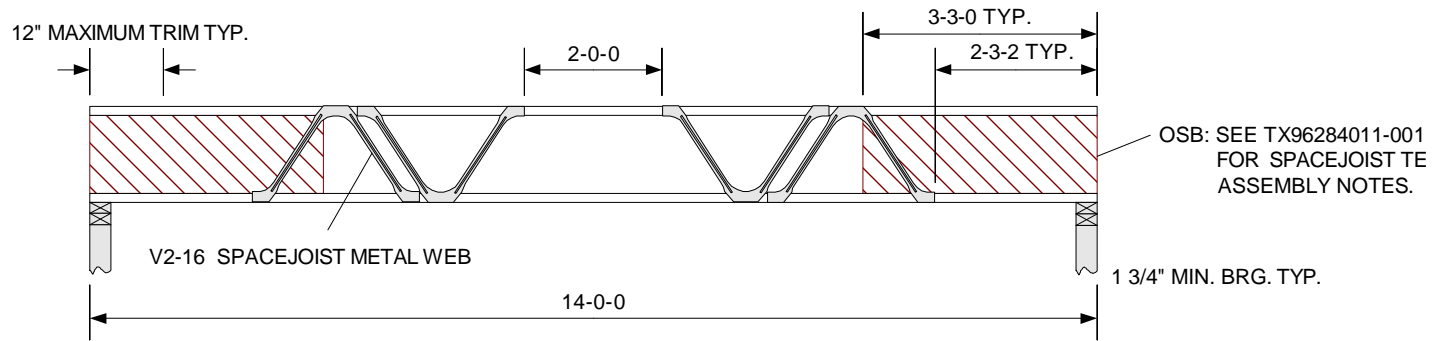

ALL WEBS ARE 20 GAUGE SPACEJOIST METAL WEBS MANUFACTURED BY TRUSWAL SYSTEMS CORPORATION.

DATE: 07-23-04
 DESIGNED BY TRUSWAL SYSTEMS



WARNING Read all notes on this sheet and give a copy of it to the Erecting Contractor.
 This design is for an individual building component, not a truss system. It has been based on specifications provided by the component manufacturer and has been completed in accordance with the current versions of TPI and AFPA design standards. No responsibility is assumed for dimensional accuracy. Dimensions are to be verified by the component manufacturer and/or building designer prior to fabrication. The building designer shall ascertain that the loads utilized on this design meet or exceed the loading imposed by the local building code and the particular application. This design assumes that the top chord is laterally braced by the roof or floor sheathing and that the bottom chord is laterally braced by a rigid sheathing material directly attached, unless otherwise noted. Bracing shown is for lateral support of individual component members only. This component shall not be placed in any environment that will cause the moisture content of the wood to exceed 19% and/or cause connector plate corrosion. Fabricate, handle, install, and brace this truss in accordance with the following standards: SPACEJOIST TRUSS FABRICATION MANUAL, by Truswal Systems; Handling, Installing, and Bracing Metal Plate Connected Wood Trusses (HIB-91 and HIB-91 Summary Sheet) by TPI. The Truss Plate Institute is located at 583 D'Onofrio Dr., Ste. 200, Madison, WI 53719. The American Forest and Paper Association (AFPA) is located at 1111 19th St. N.W., Ste. 800, Washington, DC 20036.

| | | | |
|-----------|----------------|--------------------------|---------------|
| Chk: | | Customer Name: | SpaceJoist TE |
| Dsgnr: DL | | | |
| TC Live | 40 psf | DurFacs: L= 1.00 P= 1.00 | |
| TC Dead | See Span Table | Rep Mbr Bnd: 1.15 | |
| BC Live | 0 psf | Spacing: See Span Table | |
| BC Dead | 5 psf | Design Spec: TPI | |
| TOTAL | See Span Table | | |

TOP CHORD 3X2 SPF CAN. 2100F-1.8E
 BOTTOM CHORD 3X2 SPF CAN. 2100F-1.8E
 LUMBER SHEAR ALLOWABLES ARE PER NDS-1997

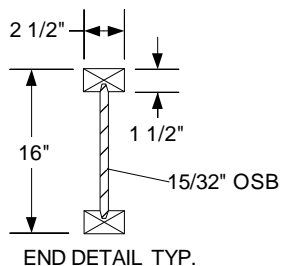

THIS TRUSS IS TRIMMABLE
 UP TO 12" MAY BE FIELD TRIMMED
 FROM EACH END OF THIS TRUSS

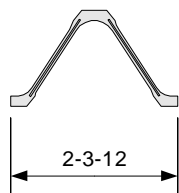

| 16" SPACEJOIST TE MAXIMUM SPANS | | | | | |
|---------------------------------|------------------|----------|------------|----------|----------|
| LOADING, PSF | DEFLECTION RATIO | SPACING | | | |
| | | 24" o.c. | 19.2" o.c. | 16" o.c. | 12" o.c. |
| 40-10-5 | L/480 | 21'- 9" | 24'- 2" | 25'- 8" | 28'- 0" |
| | L/360 | 21'- 9" | 24'- 5" | 26'- 8" | 28'- 0" |
| 40-20-5 | L/480 | 18'-3" | 22'-0" | 24'-9" | 28'-0" |
| | L/360 | 18'-3" | 22'-0" | 24'-9" | 28'-0" |

SEE TX96284011-001 FOR SPACEJOIST TE ASSEMBLY AND GENERAL NOTES

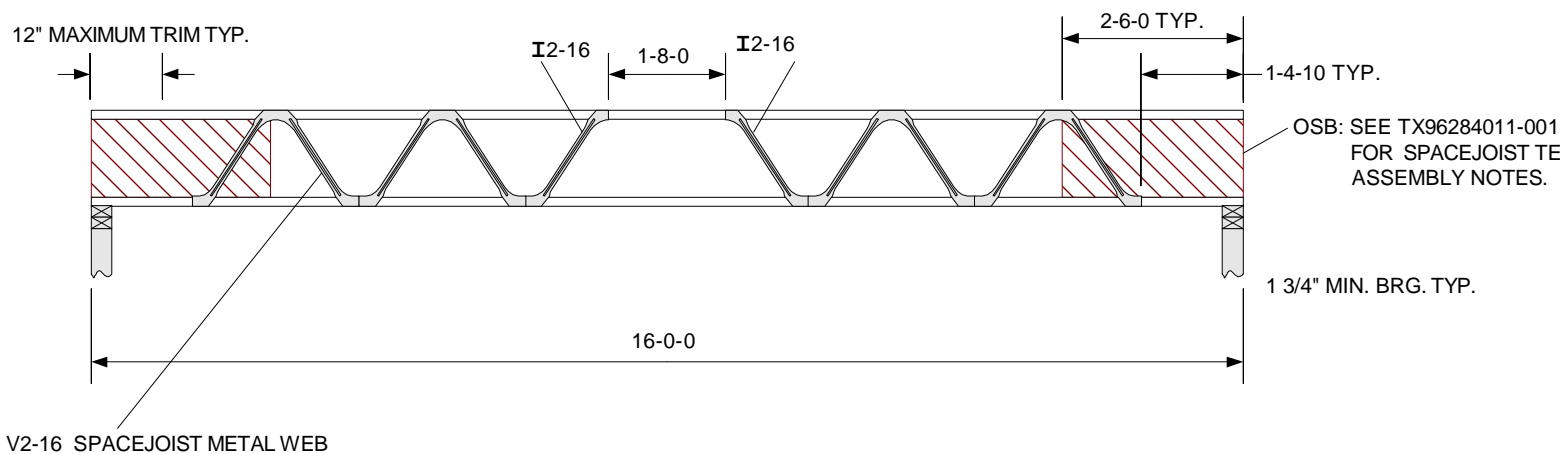

ALL WEBS ARE 20 GAUGE SPACEJOIST METAL WEBS MANUFACTURED BY TRUSWAL SYSTEMS CORPORATION.

DATE: 09-11-04

DESIGNED BY TRUSWAL SYSTEMS



WARNING Read all notes on this sheet and give a copy of it to the Erecting Contractor.
 This design is for an individual building component, not a truss system. It has been based on specifications provided by the component manufacturer and has been completed in accordance with the current versions of TPI and AFPA design standards. No responsibility is assumed for dimensional accuracy. Dimensions are to be verified by the component manufacturer and/or building designer prior to fabrication. The building designer shall ascertain that the loads utilized on this design meet or exceed the loading imposed by the local building code and the particular application. This design assumes that the top chord is laterally braced by the roof or floor sheathing and that the bottom chord is laterally braced by a rigid sheathing material directly attached, unless otherwise noted. Bracing shown is for lateral support of individual component members only. This component shall not be placed in any environment that will cause the moisture content of the wood to exceed 19% and/or cause connector plate corrosion. Fabricate, handle, install, and brace this truss in accordance with the following standards: SPACEJOIST TRUSS FABRICATION MANUAL, by Truswal Systems; Handling, Installing, and Bracing Metal Plate Connected Wood Trusses (HIB-91 and HIB-91 Summary Sheet) by TPI. The Truss Plate Institute is located at 583 D'Onofrio Dr., Ste. 200, Madison, WI 53719. The American Forest and Paper Association (AFPA) is located at 1111 19th St. N.W., Ste. 800, Washington, DC 20036.

| | |
|-----------|----------------|
| Chk: | |
| Dsgnr: DL | |
| TC Live | 40 psf |
| TC Dead | See Span Table |
| BC Live | 0 psf |
| BC Dead | 5 psf |
| TOTAL | See Span Table |

| | |
|----------------|-----------------|
| Customer Name: | SpaceJoist TE |
| DurFacs: | L= 1.00 P= 1.00 |
| Rep Mbr Bnd: | 1.15 |
| Spacing: | See Span Table |
| Design Spec: | TPI |

TOP CHORD 3X2 SPF CAN. 2100F-1.8E
 BOTTOM CHORD 3X2 SPF CAN. 2100F-1.8E
 LUMBER SHEAR ALLOWABLES ARE PER NDS-1997

| 16" SPACEJOIST TE MAXIMUM SPANS | | | | | |
|---------------------------------|------------------|----------|------------|----------|----------|
| LOADING, PSF | DEFLECTION RATIO | SPACING | | | |
| | | 24" o.c. | 19.2" o.c. | 16" o.c. | 12" o.c. |
| 40-10-5 | L/480 | 21'- 9" | 24'- 2" | 25'- 8" | 28'- 0" |
| | L/360 | 21'- 9" | 24'- 5" | 26'- 8" | 28'- 0" |
| 40-20-5 | L/480 | 18'-3" | 22'-0" | 24'-9" | 28'-0" |
| | L/360 | 18'-3" | 22'-0" | 24'-9" | 28'-0" |

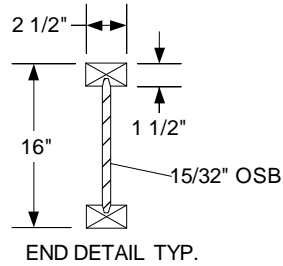

THIS TRUSS IS TRIMMABLE
 UP TO 12" MAY BE FIELD TRIMMED
 FROM EACH END OF THIS TRUSS

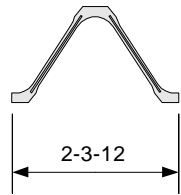

SEE TX96284011-001 FOR SPACEJOIST TE ASSEMBLY AND GENERAL NOTES

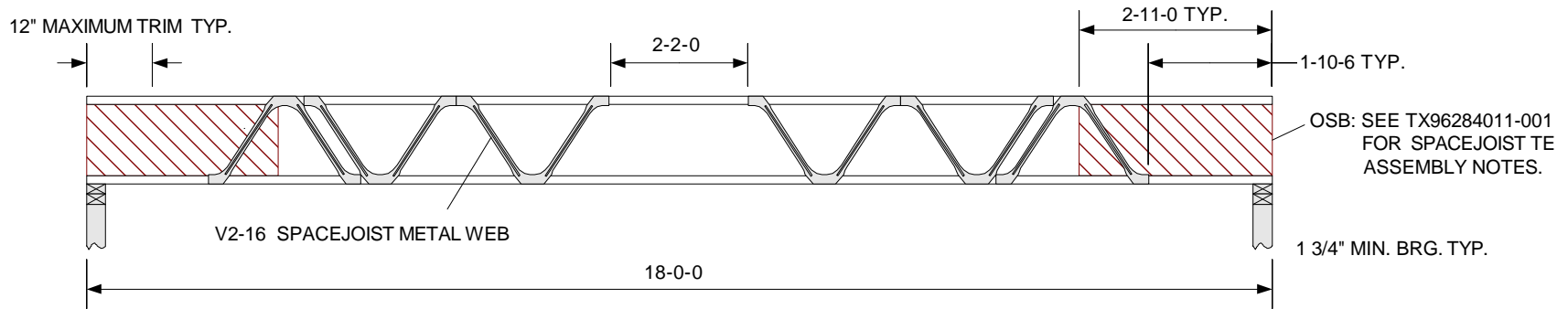

DATE: 09-11-04

ALL WEBS ARE 20 GAUGE SPACEJOIST METAL WEBS MANUFACTURED BY TRUSWAL SYSTEMS CORPORATION.

DESIGNED BY TRUSWAL SYSTEMS



WARNING Read all notes on this sheet and give a copy of it to the Erecting Contractor.
 This design is for an individual building component, not a truss system. It has been based on specifications provided by the component manufacturer and has been completed in accordance with the current versions of TPI and AFPA design standards. No responsibility is assumed for dimensional accuracy. Dimensions are to be verified by the component manufacturer and/or building designer prior to fabrication. The building designer shall ascertain that the loads utilized on this design meet or exceed the loading imposed by the local building code and the particular application. This design assumes that the top chord is laterally braced by the roof or floor sheathing and that the bottom chord is laterally braced by a rigid sheathing material directly attached, unless otherwise noted. Bracing shown is for lateral support of individual component members only. This component shall not be placed in any environment that will cause the moisture content of the wood to exceed 19% and/or cause connector plate corrosion. Fabricate, handle, install, and brace this truss in accordance with the following standards: SPACEJOIST TRUSS FABRICATION MANUAL, by Truswal Systems; Handling, Installing, and Bracing Metal Plate Connected Wood Trusses (HIB-91 and HIB-91 Summary Sheet) by TPI. The Truss Plate Institute is located at 583 D'Onofrio Dr., Ste. 200, Madison, WI 53719. The American Forest and Paper Association (AFPA) is located at 1111 19th St. N.W., Ste. 800, Washington, DC 20036.

| | |
|-----------|----------------|
| Chk: | |
| Dsgnr: DL | |
| TC Live | 40 psf |
| TC Dead | See Span Table |
| BC Live | 0 psf |
| BC Dead | 5 psf |
| TOTAL | See Span Table |

| | |
|----------------|-----------------|
| Customer Name: | SpaceJoist TE |
| DurFacs: | L= 1.00 P= 1.00 |
| Rep Mbr Bnd: | 1.15 |
| Spacing: | See Span Table |
| Design Spec: | TPI |

TOP CHORD 3X2 SPF CAN. 2100F-1.8E
 BOTTOM CHORD 3X2 SPF CAN. 2100F-1.8E
 LUMBER SHEAR ALLOWABLES ARE PER NDS-1997

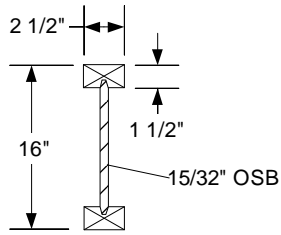

END DETAIL TYP.

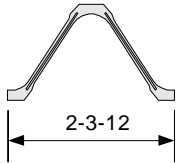

| 16" SPACEJOIST TE MAXIMUM SPANS | | | | | |
|---------------------------------|------------------|----------|------------|----------|----------|
| LOADING, PSF | DEFLECTION RATIO | SPACING | | | |
| | | 24" o.c. | 19.2" o.c. | 16" o.c. | 12" o.c. |
| 40-10-5 | L/480 | 21'- 9" | 24'- 2" | 25'- 8" | 28'- 0" |
| | L/360 | 21'- 9" | 24'- 5" | 26'- 8" | 28'- 0" |
| 40-20-5 | L/480 | 18'-3" | 22'-0" | 24'-9" | 28'-0" |
| | L/360 | 18'-3" | 22'-0" | 24'-9" | 28'-0" |

THIS TRUSS IS TRIMMABLE

UP TO 12" MAY BE FIELD TRIMMED FROM EACH END OF THIS TRUSS

SEE TX96284011-001 FOR SPACEJOIST TE ASSEMBLY AND GENERAL NOTES

OSB: SEE TX96284011-001 FOR SPACEJOIST TE ASSEMBLY NOTES.

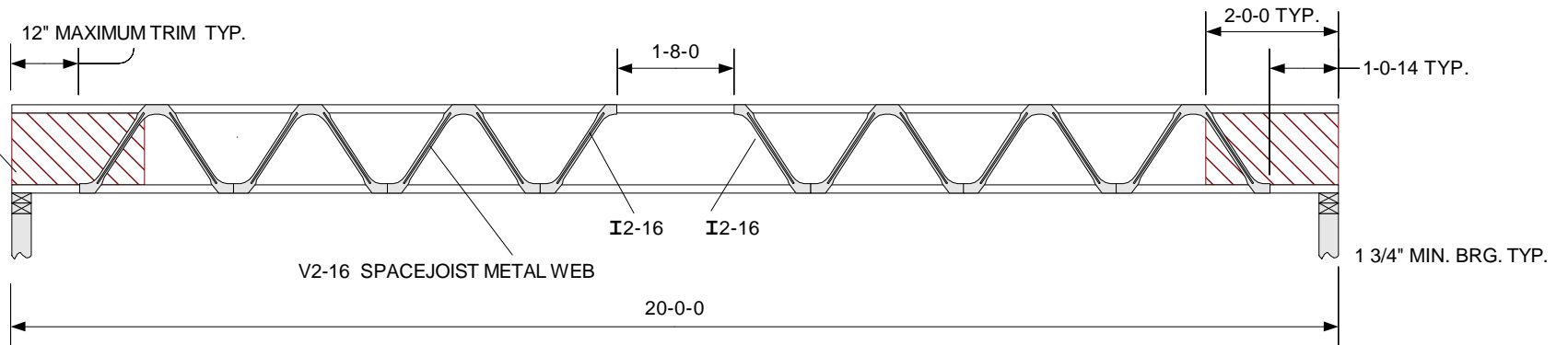

DATE: 09-11-04

ALL WEBS ARE 20 GAUGE SPACEJOIST METAL WEBS MANUFACTURED BY TRUSWAL SYSTEMS CORPORATION.

DESIGNED BY TRUSWAL SYSTEMS



WARNING Read all notes on this sheet and give a copy of it to the Erecting Contractor. This design is for an individual building component, not a truss system. It has been based on specifications provided by the component manufacturer and has been completed in accordance with the current versions of TPI and AFPA design standards. No responsibility is assumed for dimensional accuracy. Dimensions are to be verified by the component manufacturer and/or building designer prior to fabrication. The building designer shall ascertain that the loads utilized on this design meet or exceed the loading imposed by the local building code and the particular application. This design assumes that the top chord is laterally braced by the roof or floor sheathing and that the bottom chord is laterally braced by a rigid sheathing material directly attached, unless otherwise noted. Bracing shown is for lateral support of individual component members only. This component shall not be placed in any environment that will cause the moisture content of the wood to exceed 19% and/or cause connector plate corrosion. Fabricate, handle, install, and brace this truss in accordance with the following standards: *SPACEJOIST TRUSS FABRICATION MANUAL*, by Truswal Systems; *Handling, Installing, and Bracing Metal Plate Connected Wood Trusses* (HIB-91 and HIB-91 Summary Sheet) by TPI. The Truss Plate Institute is located at 583 D'Onofrio Dr., Ste. 200, Madison, WI 53719. The American Forest and Paper Association (AFPA) is located at 1111 19th St. N.W., Ste. 800, Washington, DC 20036.

| | |
|-----------|----------------|
| Chk: | |
| Dsgnr: DL | |
| TC Live | 40 psf |
| TC Dead | See Span Table |
| BC Live | 0 psf |
| BC Dead | 5 psf |
| TOTAL | See Span Table |

| | |
|----------------|-----------------|
| Customer Name: | SpaceJoist TE |
| DurFacs: | L= 1.00 P= 1.00 |
| Rep Mbr Bnd: | 1.15 |
| Spacing: | See Span Table |
| Design Spec: | TPI |

TOP CHORD 3X2 SPF CAN. 2100F-1.8E
 BOTTOM CHORD 3X2 SPF CAN. 2100F-1.8E
 LUMBER SHEAR ALLOWABLES ARE PER NDS-1997

| 16" SPACEJOIST TE MAXIMUM SPANS | | | | | |
|---------------------------------|------------------|----------|------------|----------|----------|
| LOADING, PSF | DEFLECTION RATIO | SPACING | | | |
| | | 24" o.c. | 19.2" o.c. | 16" o.c. | 12" o.c. |
| 40-10-5 | L/480 | 21'- 9" | 24'- 2" | 25'- 8" | 28'- 0" |
| | L/360 | 21'- 9" | 24'- 5" | 26'- 8" | 28'- 0" |
| 40-20-5 | L/480 | 18'-3" | 22'-0" | 24'-9" | 28'-0" |
| | L/360 | 18'-3" | 22'-0" | 24'-9" | 28'-0" |

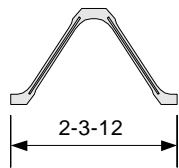
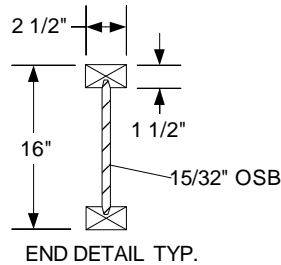

THIS TRUSS IS TRIMMABLE
 UP TO 12" MAY BE FIELD-TRIMMED FROM EACH END OF THIS TRUSS.
 SEE TX96284011-001 FOR SPACEJOIST TE ASSEMBLY AND GENERAL NOTES

OSB: SEE TX96284011-001 FOR SPACEJOIST TE ASSEMBLY NOTES.

12" MAXIMUM TRIM TYP.

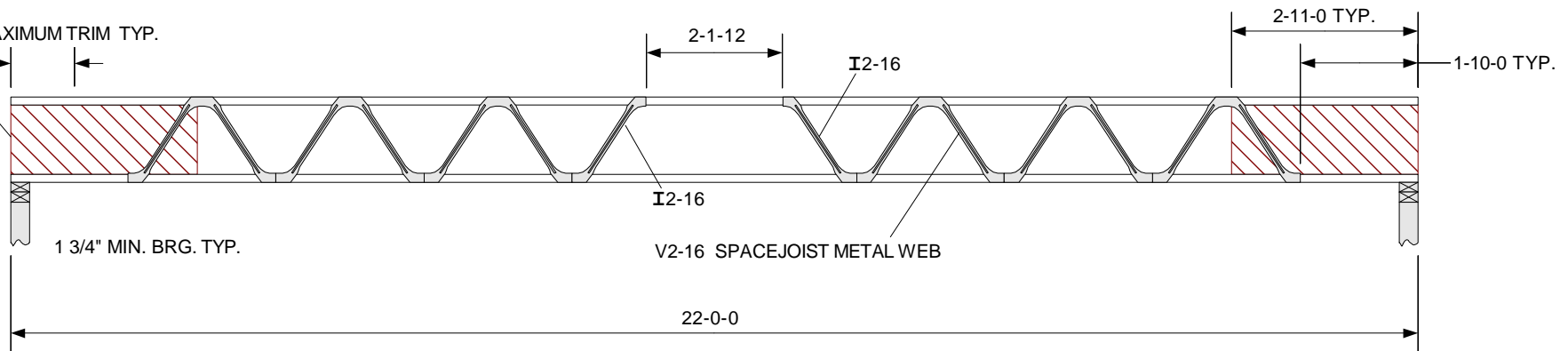

ALL WEBS ARE 20 GAUGE SPACEJOIST METAL WEBS MANUFACTURED BY TRUSWAL SYSTEMS CORPORATION.

DATE: 09-11-04
 DESIGNED BY TRUSWAL SYSTEMS



WARNING Read all notes on this sheet and give a copy of it to the Erecting Contractor.
 This design is for an individual building component, not a truss system. It has been based on specifications provided by the component manufacturer and has been completed in accordance with the current versions of TPI and AFPA design standards. No responsibility is assumed for dimensional accuracy. Dimensions are to be verified by the component manufacturer and/or building designer prior to fabrication. The building designer shall ascertain that the loads utilized on this design meet or exceed the loading imposed by the local building code and the particular application. This design assumes that the top chord is laterally braced by the roof or floor sheathing and that the bottom chord is laterally braced by a rigid sheathing material directly attached, unless otherwise noted. Bracing shown is for lateral support of individual component members only. This component shall not be placed in any environment that will cause the moisture content of the wood to exceed 19% and/or cause connector plate corrosion. Fabricate, handle, install, and brace this truss in accordance with the following standards: SPACEJOIST TRUSS FABRICATION MANUAL, by Truswal Systems; Handling, Installing, and Bracing Metal Plate Connected Wood Trusses (HIB-91 and HIB-91 Summary Sheet) by TPI. The Truss Plate Institute is located at 583 D'Onofrio Dr., Ste. 200, Madison, WI 53719. The American Forest and Paper Association (AFPA) is located at 1111 19th St. N.W., Ste. 800, Washington, DC 20036.

| | |
|-----------|----------------|
| Chk: | |
| Dsgnr: DL | |
| TC Live | 40 psf |
| TC Dead | See Span Table |
| BC Live | 0 psf |
| BC Dead | 5 psf |
| TOTAL | See Span Table |

| | |
|----------------|-----------------|
| Customer Name: | SpaceJoist TE |
| DurFacs: | L= 1.00 P= 1.00 |
| Rep Mbr Bnd: | 1.15 |
| Spacing: | See Span Table |
| Design Spec: | TPI |

TOP CHORD 3X2 SPF CAN. 2100F-1.8E
 BOTTOM CHORD 3X2 SPF CAN. 2100F-1.8E
 LUMBER SHEAR ALLOWABLES ARE PER NDS-1997

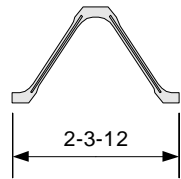
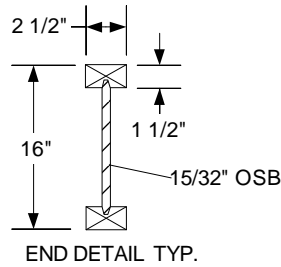

| 16" SPACEJOIST TE MAXIMUM SPANS | | | | | |
|---------------------------------|------------------|----------|------------|----------|----------|
| LOADING, PSF | DEFLECTION RATIO | SPACING | | | |
| | | 24" o.c. | 19.2" o.c. | 16" o.c. | 12" o.c. |
| 40-10-5 | L/480 | 21'- 9" | 24'- 2" | 25'- 8" | 28'- 0" |
| | L/360 | 21'- 9" | 24'- 5" | 26'- 8" | 28'- 0" |
| 40-20-5 | L/480 | 18'-3" | 22'-0" | 24'-9" | 28'-0" |
| | L/360 | 18'-3" | 22'-0" | 24'-9" | 28'-0" |

THIS TRUSS IS TRIMMABLE
 UP TO 12" MAY BE FIELD TRIMMED
 FROM EACH END OF THIS TRUSS

SEE TX96284011-001 FOR SPACEJOIST TE
 ASSEMBLY AND GENERAL NOTES

OSB: SEE TX96284011-001 FOR
 SPACEJOIST TE ASSEMBLY NOTES.

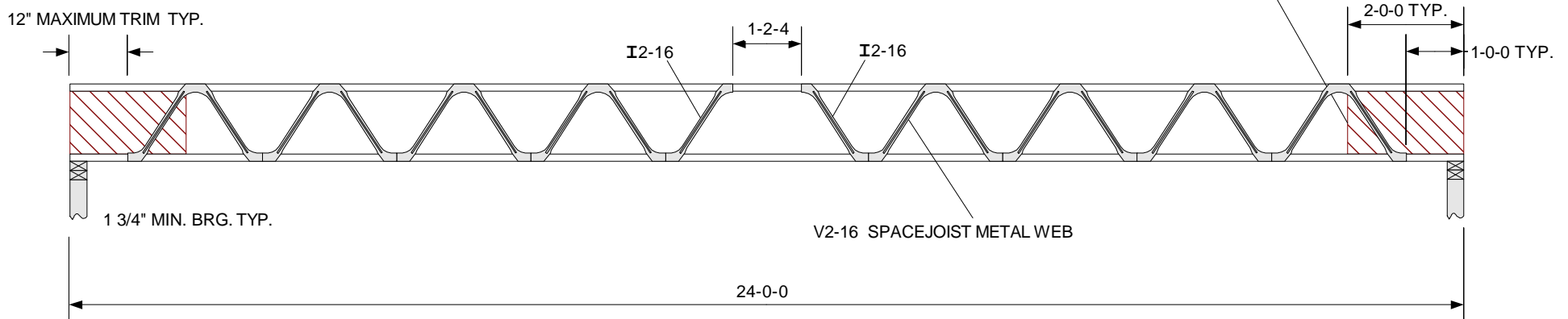

ALL WEBS ARE 20 GAUGE SPACEJOIST METAL WEBS MANUFACTURED BY TRUSWAL SYSTEMS CORPORATION.

DATE: 09-11-04
 DESIGNED BY TRUSWAL SYSTEMS



WARNING Read all notes on this sheet and give a copy of it to the Erecting Contractor.
 This design is for an individual building component, not a truss system. It has been based on specifications provided by the component manufacturer and has been completed in accordance with the current versions of TPI and AFPA design standards. No responsibility is assumed for dimensional accuracy. Dimensions are to be verified by the component manufacturer and/or building designer prior to fabrication. The building designer shall ascertain that the loads utilized on this design meet or exceed the loading imposed by the local building code and the particular application. This design assumes that the top chord is laterally braced by the roof or floor sheathing and that the bottom chord is laterally braced by a rigid sheathing material directly attached, unless otherwise noted. Bracing shown is for lateral support of individual component members only. This component shall not be placed in any environment that will cause the moisture content of the wood to exceed 19% and/or cause connector plate corrosion. Fabricate, handle, install, and brace this truss in accordance with the following standards: *SPACEJOIST TRUSS FABRICATION MANUAL*, by Truswal Systems; *Handling, Installing, and Bracing Metal Plate Connected Wood Trusses* (HIB-91 and HIB-91 Summary Sheet) by TPI. The Truss Plate Institute is located at 583 D'Onofrio Dr., Ste. 200, Madison, WI 53719. The American Forest and Paper Association (AFPA) is located at 1111 19th St. N.W., Ste. 800, Washington, DC 20036.

| | |
|-----------|----------------|
| Chk: | |
| Dsgnr: DL | |
| TC Live | 40 psf |
| TC Dead | See Span Table |
| BC Live | 0 psf |
| BC Dead | 5 psf |
| TOTAL | See Span Table |

| | |
|----------------|-----------------|
| Customer Name: | SpaceJoist TE |
| DurFacs: | L= 1.00 P= 1.00 |
| Rep Mbr Bnd: | 1.15 |
| Spacing: | See Span Table |
| Design Spec: | TPI |

TOP CHORD 3X2 SPF CAN. 2100F-1.8E
 BOTTOM CHORD 3X2 SPF CAN. 2100F-1.8E
 LUMBER SHEAR ALLOWABLES ARE PER NDS-1997

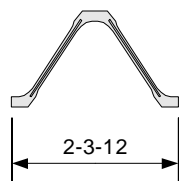
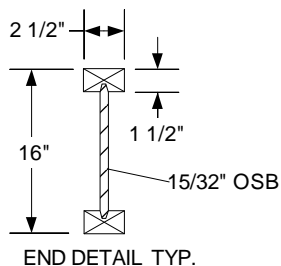

| 16" SPACEJOIST TE MAXIMUM SPANS | | | | | |
|---------------------------------|------------------|----------|------------|----------|----------|
| LOADING, PSF | DEFLECTION RATIO | SPACING | | | |
| | | 24" o.c. | 19.2" o.c. | 16" o.c. | 12" o.c. |
| 40-10-5 | L/480 | 21'- 9" | 24'- 2" | 25'- 8" | 28'- 0" |
| | L/360 | 21'- 9" | 24'- 5" | 26'- 8" | 28'- 0" |
| 40-20-5 | L/480 | 18'- 3" | 22'- 0" | 24'- 9" | 28'- 0" |
| | L/360 | 18'- 3" | 22'- 0" | 24'- 9" | 28'- 0" |

THIS TRUSS IS TRIMMABLE
 UP TO 12" MAY BE FIELD TRIMMED
 FROM EACH END OF THIS TRUSS

SEE TX96284011-001 FOR SPACEJOIST TE ASSEMBLY AND GENERAL NOTES

OSB: SEE TX96284011-001 FOR SPACEJOIST TE ASSEMBLY NOTES.

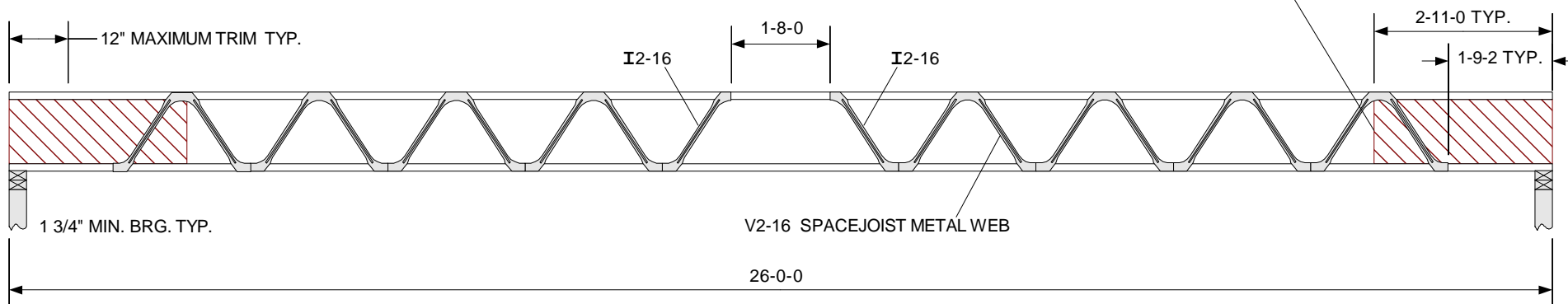

ALL WEBS ARE 20 GAUGE SPACEJOIST METAL WEBS MANUFACTURED BY TRUSWAL SYSTEMS CORPORATION.

DATE: 10-20-04
 DESIGNED BY TRUSWAL SYSTEMS



WARNING Read all notes on this sheet and give a copy of it to the Erecting Contractor.
 This design is for an individual building component, not a truss system. It has been based on specifications provided by the component manufacturer and has been completed in accordance with the current versions of TPI and AFPA design standards. No responsibility is assumed for dimensional accuracy. Dimensions are to be verified by the component manufacturer and/or building designer prior to fabrication. The building designer shall ascertain that the loads utilized on this design meet or exceed the loading imposed by the local building code and the particular application. This design assumes that the top chord is laterally braced by the roof or floor sheathing and that the bottom chord is laterally braced by a rigid sheathing material directly attached, unless otherwise noted. Bracing shown is for lateral support of individual component members only. This component shall not be placed in any environment that will cause the moisture content of the wood to exceed 19% and/or cause connector plate corrosion. Fabricate, handle, install, and brace this truss in accordance with the following standards: SPACEJOIST TRUSS FABRICATION MANUAL, by Truswal Systems; Handling, Installing, and Bracing Metal Plate Connected Wood Trusses (HIB-91 and HIB-91 Summary Sheet) by TPI. The Truss Plate Institute is located at 583 D'Onofrio Dr., Ste. 200, Madison, WI 53719. The American Forest and Paper Association (AFPA) is located at 1111 19th St. N.W., Ste. 800, Washington, DC 20036.

| | |
|--|--|
| Chk: Dsgnr: DL | Customer Name: Spacejoist TE |
| TC Live 40 psf TC Dead See Span Table BC Live 0 psf BC Dead 5 psf TOTAL See Span Table | DurFacs: L= 1.00 P= 1.00 Rep Mbr Bnd: 1.15 Spacing: See Span Table Design Spec: TPI |

TOP CHORD 3X2 SPF CAN. 2100F-1.8E
 BOTTOM CHORD 3X2 SPF CAN. 2100F-1.8E
 LUMBER SHEAR ALLOWABLES ARE PER NDS-1997

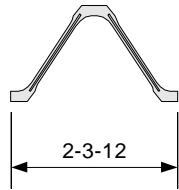
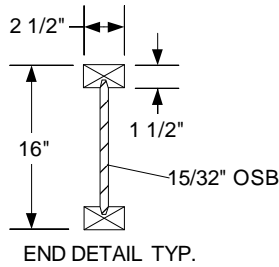

| 16" SPACEJOIST TE MAXIMUM SPANS | | | | | |
|---------------------------------|------------------|----------|------------|----------|----------|
| LOADING, PSF | DEFLECTION RATIO | SPACING | | | |
| | | 24" o.c. | 19.2" o.c. | 16" o.c. | 12" o.c. |
| 40-10-5 | L/480 | 21'- 9" | 24'- 2" | 25'- 8" | 28'- 0" |
| | L/360 | 21'- 9" | 24'- 5" | 26'- 8" | 28'- 0" |
| 40-20-5 | L/480 | 18'-3" | 22'-0" | 24'-9" | 28'-0" |
| | L/360 | 18'-3" | 22'-0" | 24'-9" | 28'-0" |

THIS TRUSS IS TRIMMABLE
 UP TO 12" MAY BE FIELD TRIMMED
 FROM EACH END OF THIS TRUSS

SEE TX96284011-001 FOR SPACEJOIST TE
 ASSEMBLY AND GENERAL NOTES

OSB: SEE TX96284011-001 FOR
 SPACEJOIST TE ASSEMBLY NOTES.

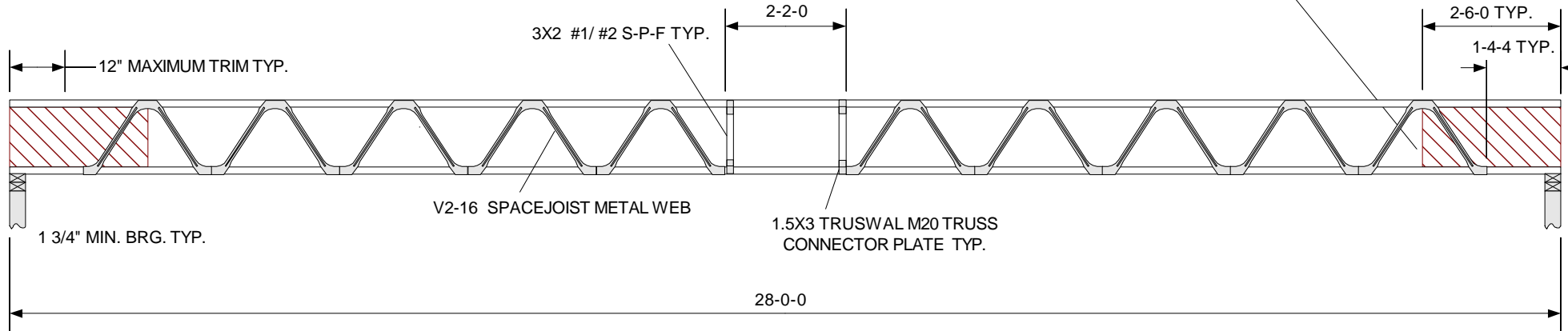

ALL WEBS ARE 20 GAUGE SPACEJOIST METAL WEBS MANUFACTURED BY TRUSWAL SYSTEMS CORPORATION.

DATE: 10-20-04

DESIGNED BY TRUSWAL SYSTEMS



WARNING Read all notes on this sheet and give a copy of it to the Erecting Contractor.
 This design is for an individual building component, not a truss system. It has been based on specifications provided by the component manufacturer and has been completed in accordance with the current versions of TPI and AFPA design standards. No responsibility is assumed for dimensional accuracy. Dimensions are to be verified by the component manufacturer and/or building designer prior to fabrication. The building designer shall ascertain that the loads utilized on this design meet or exceed the loading imposed by the local building code and the particular application. This design assumes that the top chord is laterally braced by the roof or floor sheathing and that the bottom chord is laterally braced by a rigid sheathing material directly attached, unless otherwise noted. Bracing shown is for lateral support of individual component members only. This component shall not be placed in any environment that will cause the moisture content of the wood to exceed 19% and/or cause connector plate corrosion. Fabricate, handle, install, and brace this truss in accordance with the following standards: SPACEJOIST TRUSS FABRICATION MANUAL, by Truswal Systems; Handling, Installing, and Bracing Metal Plate Connected Wood Trusses (HIB-91 and HIB-91 Summary Sheet) by TPI. The Truss Plate Institute is located at 583 D'Onofrio Dr., Ste. 200, Madison, WI 53719. The American Forest and Paper Association (AFPA) is located at 1111 19th St. N.W., Ste. 800, Washington, DC 20036.

| | |
|--|--|
| Chk: Dsgnr: DL | Customer Name: SpaceJoist TE |
| TC Live 40 psf TC Dead See Span Table BC Live 0 psf BC Dead 5 psf TOTAL See Span Table | DurFacs: L= 1.00 P= 1.00 Rep Mbr Bnd: 1.15 Spacing: See Span Table Design Spec: TPI |