

Scroll Down to see the Technical Drawings

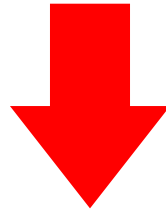

TOP CHORD 4X2 SPF CAN. 1650F-1.5E  
 BOTTOM CHORD 4X2 SPF CAN. 1650F-1.5E  
 LUMBER SHEAR ALLOWABLES ARE PER NDS-1997

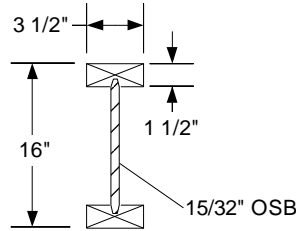

END DETAIL TYP.

16" SPACEJOIST TE MAXIMUM SPANS					
LOADING, PSF	DEFLECTION RATIO	SPACING			
		24" o.c.	19.2" o.c.	16" o.c.	12" o.c.
40-10-5	L/480	22'-0"	26'-0"	28'-6"	30'-0"
	L/360	22'-0"	26'-0"	30'-0"	30'-0"
40-20-5	L/480	18'-3"	22'-0"	26'-0"	30'-0"
	L/360	18'-3"	22'-0"	26'-0"	30'-0"

**THIS TRUSS IS TRIMMABLE**

UP TO 12" MAY BE FIELD-TRIMMED FROM EACH END OF THIS JOIST

SEE TX96284011-001 FOR SPACEJOIST TE ASSEMBLY AND GENERAL NOTES

OSB: SEE TX96284011-001 FOR SPACEJOIST TE ASSEMBLY NOTES.

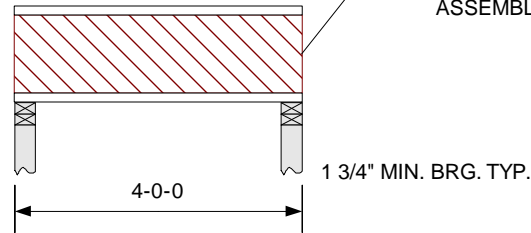

ALL WEBS ARE 20 GAUGE SPACEJOIST METAL WEBS MANUFACTURED BY TRUSWAL SYSTEMS CORPORATION.

DATE: 02-15-05  
 DESIGNED BY TRUSWAL SYSTEMS

*Trimnable End*

**SpaceJoist™**

1101 North Great Southwest Parkway  
 Arlington, Texas 76011

**WARNING** Read all notes on this sheet and give a copy of it to the Erecting Contractor.  
 This design is for an individual building component, not a truss system. It has been based on specifications provided by the component manufacturer and has been completed in accordance with the current versions of TPI and AFPA design standards. No responsibility is assumed for dimensional accuracy. Dimensions are to be verified by the component manufacturer and/or building designer prior to fabrication. The building designer shall ascertain that the loads utilized on this design meet or exceed the loading imposed by the local building code and the particular application. This design assumes that the top chord is laterally braced by the roof or floor sheathing and that the bottom chord is laterally braced by a rigid sheathing material directly attached, unless otherwise noted. Bracing shown is for lateral support of individual component members only. This component shall not be placed in any environment that will cause the moisture content of the wood to exceed 19% and/or cause connector plate corrosion. Fabricate, handle, install, and brace this truss in accordance with the following standards: SPACEJOIST TRUSS FABRICATION MANUAL, by Truswal Systems; Handling, Installing, and Bracing Metal Plate Connected Wood Trusses (HIB-91 and HIB-91 Summary Sheet) by TPI. The Truss Plate Institute is located at 583 D'Onofrio Dr., Ste. 200, Madison, WI 53719. The American Forest and Paper Association (AFPA) is located at 1111 19th St. N.W., Ste. 800, Washington, DC 20036.

Chk:		Customer Name:	SpaceJoist TE
Dsgnr:	DL		
TC Live	40 psf	DurFacs:	L= 1.00 P= 1.00
TC Dead	See Span Table	Rep Mbr Bnd:	1.15
BC Live	0 psf	Spacing:	See Span Table
BC Dead	5 psf	Design Spec:	TPI
TOTAL	See Span Table		

TOP CHORD 4X2 SPF CAN. 1650F-1.5E  
 BOTTOM CHORD 4X2 SPF CAN. 1650F-1.5E  
 LUMBER SHEAR ALLOWABLES ARE PER NDS-1997

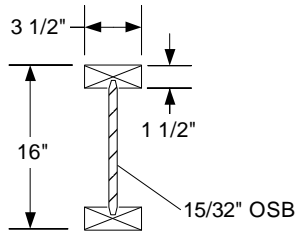

END DETAIL TYP.

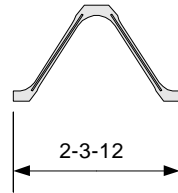

16" SPACEJOIST TE MAXIMUM SPANS					
LOADING, PSF	DEFLECTION RATIO	SPACING			
		24" o.c.	19.2" o.c.	16" o.c.	12" o.c.
40-10-5	L/480	22'-0"	26'-0"	28'-6"	30'-0"
	L/360	22'-0"	26'-0"	30'-0"	30'-0"
40-20-5	L/480	18'-3"	22'-0"	26'-0"	30'-0"
	L/360	18'-3"	22'-0"	26'-0"	30'-0"

**THIS TRUSS IS TRIMMABLE**

UP TO 18" MAY BE FIELD TRIMMED FROM EACH END OF THIS TRUSS

SEE TX96284011-001 FOR SPACEJOIST TE ASSEMBLY AND GENERAL NOTES

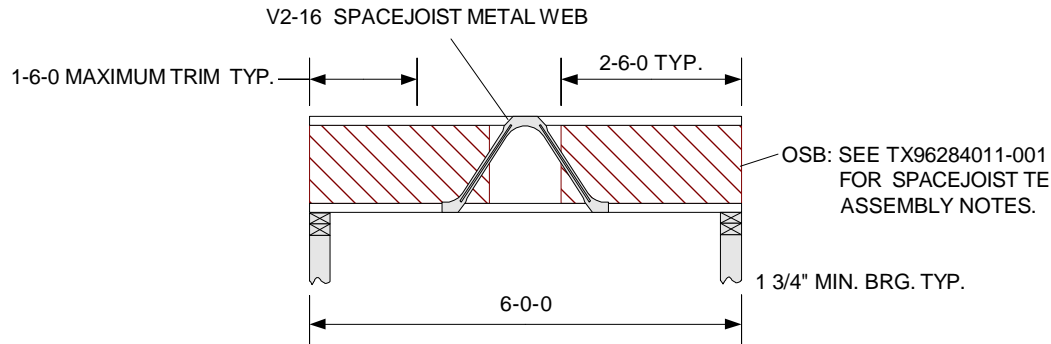

DATE: 02-15-05

ALL WEBS ARE 20 GAUGE SPACEJOIST METAL WEBS MANUFACTURED BY TRUSWAL SYSTEMS CORPORATION.

DESIGNED BY TRUSWAL SYSTEMS



**WARNING** Read all notes on this sheet and give a copy of it to the Erecting Contractor. This design is for an individual building component, not a truss system. It has been based on specifications provided by the component manufacturer and has been completed in accordance with the current versions of TPI and AFPA design standards. No responsibility is assumed for dimensional accuracy. Dimensions are to be verified by the component manufacturer and/or building designer prior to fabrication. The building designer shall ascertain that the loads utilized on this design meet or exceed the loading imposed by the local building code and the particular application. This design assumes that the top chord is laterally braced by the roof or floor sheathing and that the bottom chord is laterally braced by a rigid sheathing material directly attached, unless otherwise noted. Bracing shown is for lateral support of individual component members only. This component shall not be placed in any environment that will cause the moisture content of the wood to exceed 19% and/or cause connector plate corrosion. Fabricate, handle, install, and brace this truss in accordance with the following standards: SPACEJOIST TRUSS FABRICATION MANUAL, by Truswal Systems; Handling, Installing, and Bracing Metal Plate Connected Wood Trusses (HIB-91 and HIB-91 Summary Sheet) by TPI. The Truss Plate Institute is located at 583 D'Onofrio Dr., Ste. 200, Madison, WI 53719. The American Forest and Paper Association (AFPA) is located at 1111 19th St. N.W., Ste. 800, Washington, DC 20036.

Chk:	
Dsgnr: DL	
TC Live	40 psf
TC Dead	See Span Table
BC Live	0 psf
BC Dead	5 psf
TOTAL	See Span Table

Customer Name:	SpaceJoist TE
DurFacs:	L= 1.00 P= 1.00
Rep Mbr Bnd:	1.15
Spacing:	See Span Table
Design Spec:	TPI

TOP CHORD 4X2 SPF CAN. 1650F-1.5E  
 BOTTOM CHORD 4X2 SPF CAN. 1650F-1.5E  
 LUMBER SHEAR ALLOWABLES ARE PER NDS-1997

16" SPACEJOIST TE MAXIMUM SPANS					
LOADING, PSF	DEFLECTION RATIO	SPACING			
		24" o.c.	19.2" o.c.	16" o.c.	12" o.c.
40-10-5	L/480	22'-0"	26'-0"	28'-6"	30'-0"
	L/360	22'-0"	26'-0"	30'-0"	30'-0"
40-20-5	L/480	18'-3"	22'-0"	26'-0"	30'-0"
	L/360	18'-3"	22'-0"	26'-0"	30'-0"

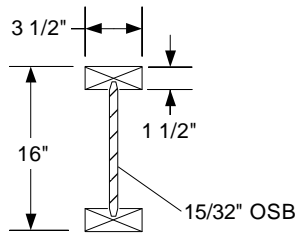

END DETAIL TYP.

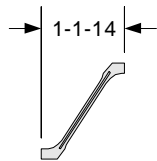

**THIS TRUSS IS TRIMMABLE**

UP TO 12" MAY BE FIELD TRIMMED FROM EACH END OF THIS TRUSS

SEE TX96284011-001 FOR SPACEJOIST TE ASSEMBLY AND GENERAL NOTES

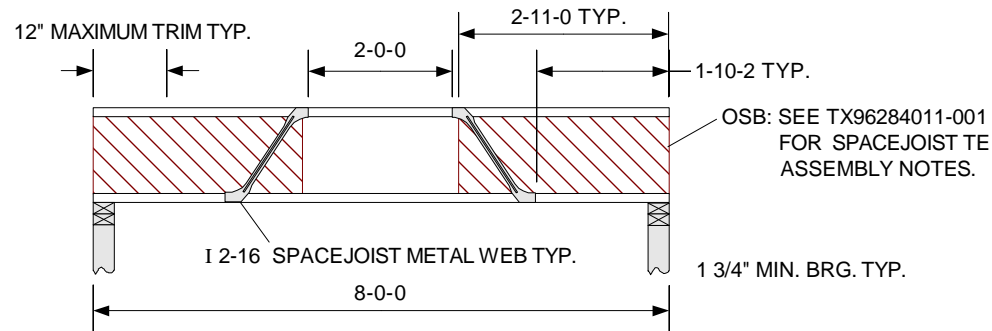

ALL WEBS ARE 20 GAUGE SPACEJOIST METAL WEBS MANUFACTURED BY TRUSWAL SYSTEMS CORPORATION.

DATE: 02-15-05  
 DESIGNED BY TRUSWAL SYSTEMS



**WARNING** Read all notes on this sheet and give a copy of it to the Erecting Contractor. This design is for an individual building component, not a truss system. It has been based on specifications provided by the component manufacturer and has been completed in accordance with the current versions of TPI and AFPA design standards. No responsibility is assumed for dimensional accuracy. Dimensions are to be verified by the component manufacturer and/or building designer prior to fabrication. The building designer shall ascertain that the loads utilized on this design meet or exceed the loading imposed by the local building code and the particular application. This design assumes that the top chord is laterally braced by the roof or floor sheathing and that the bottom chord is laterally braced by a rigid sheathing material directly attached, unless otherwise noted. Bracing shown is for lateral support of individual component members only. This component shall not be placed in any environment that will cause the moisture content of the wood to exceed 19% and/or cause connector plate corrosion. Fabricate, handle, install, and brace this truss in accordance with the following standards: SPACEJOIST TRUSS FABRICATION MANUAL, by Truswal Systems; Handling, Installing, and Bracing Metal Plate Connected Wood Trusses (HIB-91 and HIB-91 Summary Sheet) by TPI. The Truss Plate Institute is located at 583 D'Onofrio Dr., Ste. 200, Madison, WI 53719. The American Forest and Paper Association (AFPA) is located at 1111 19th St. N.W., Ste. 800, Washington, DC 20036.

Chk:		Customer Name:	SpaceJoist TE
Dsgnr: DL			
TC Live	40 psf	DurFacs: L= 1.00 P= 1.00	
TC Dead	See Span Table	Rep Mbr Bnd: 1.15	
BC Live	0 psf	Spacing: See Span Table	
BC Dead	5 psf	Design Spec: TPI	
TOTAL	See Span Table		

TOP CHORD 4X2 SPF CAN. 1650F-1.5E  
 BOTTOM CHORD 4X2 SPF CAN. 1650F-1.5E  
 LUMBER SHEAR ALLOWABLES ARE PER NDS-1997

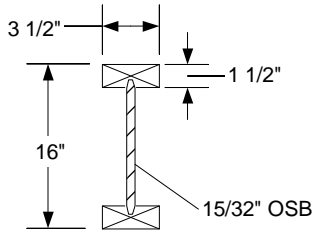

END DETAIL TYP.

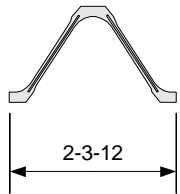

16" SPACEJOIST TE MAXIMUM SPANS					
LOADING, PSF	DEFLECTION RATIO	SPACING			
		24" o.c.	19.2" o.c.	16" o.c.	12" o.c.
40-10-5	L/480	22'-0"	26'-0"	28'-6"	30'-0"
	L/360	22'-0"	26'-0"	30'-0"	30'-0"
40-20-5	L/480	18'-3"	22'-0"	26'-0"	30'-0"
	L/360	18'-3"	22'-0"	26'-0"	30'-0"

**THIS TRUSS IS TRIMMABLE**

UP TO 12" MAY BE FIELD TRIMMED FROM EACH END OF THIS TRUSS

SEE TX96284011-001 FOR SPACEJOIST TE ASSEMBLY AND GENERAL NOTES

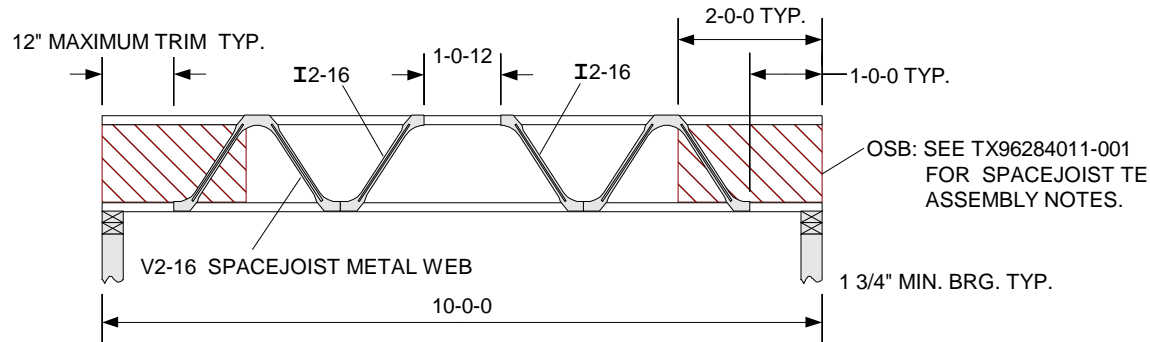

ALL WEBS ARE 20 GAUGE SPACEJOIST METAL WEBS MANUFACTURED BY TRUSWAL SYSTEMS CORPORATION .

DATE: 02-15-05  
 Designed by Truswal Systems



**WARNING** Read all notes on this sheet and give a copy of it to the Erecting Contractor.  
 This design is for an individual building component, not a truss system. It has been based on specifications provided by the component manufacturer and has been completed in accordance with the current versions of TPI and AFPA design standards. No responsibility is assumed for dimensional accuracy. Dimensions are to be verified by the component manufacturer and/or building designer prior to fabrication. The building designer shall ascertain that the loads utilized on this design meet or exceed the loading imposed by the local building code and the particular application. This design assumes that the top chord is laterally braced by the roof or floor sheathing and that the bottom chord is laterally braced by a rigid sheathing material directly attached, unless otherwise noted. Bracing shown is for lateral support of individual component members only. This component shall not be placed in any environment that will cause the moisture content of the wood to exceed 19% and/or cause connector plate corrosion. Fabricate, handle, install, and brace this truss in accordance with the following standards: SPACEJOIST TRUSS FABRICATION MANUAL, by Truswal Systems; Handling, Installing, and Bracing Metal Plate Connected Wood Trusses (HIB-91 and HIB-91 Summary Sheet) by TPI. The Truss Plate Institute is located at 583 D'Onofrio Dr., Ste. 200, Madison, WI 53719. The American Forest and Paper Association (AFPA) is located at 1111 19th St. N.W., Ste. 800, Washington, DC 20036.

Chk:		Customer Name:	SpaceJoist TE
Dsgnr: DL			
TC Live	40 psf	DurFacs:	L= 1.00 P= 1.00
TC Dead	See Span Table	Rep Mbr Bnd:	1.15
BC Live	0 psf	Spacing:	See Span Table
BC Dead	5 psf	Design Spec:	TPI
Total Load	See Span Table		

TOP CHORD 4X2 SPF CAN. 1650F-1.5E  
 BOTTOM CHORD 4X2 SPF CAN. 1650F-1.5E  
 LUMBER SHEAR ALLOWABLES ARE PER NDS-1997

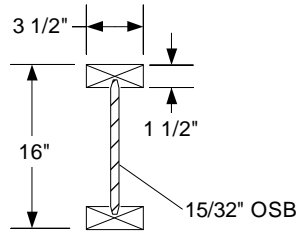

END DETAIL TYP.

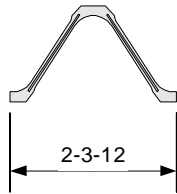

16" SPACEJOIST TE MAXIMUM SPANS					
LOADING, PSF	DEFLECTION RATIO	SPACING			
		24" o.c.	19.2" o.c.	16" o.c.	12" o.c.
40-10-5	L/480	22'-0"	26'-0"	28'-6"	30'-0"
	L/360	22'-0"	26'-0"	30'-0"	30'-0"
40-20-5	L/480	18'-3"	22'-0"	26'-0"	30'-0"
	L/360	18'-3"	22'-0"	26'-0"	30'-0"

**THIS TRUSS IS TRIMMABLE**

UP TO 12" MAY BE FIELD TRIMMED FROM EACH END OF THIS TRUSS

SEE TX96284011-001 FOR SPACEJOIST TE ASSEMBLY AND GENERAL NOTES

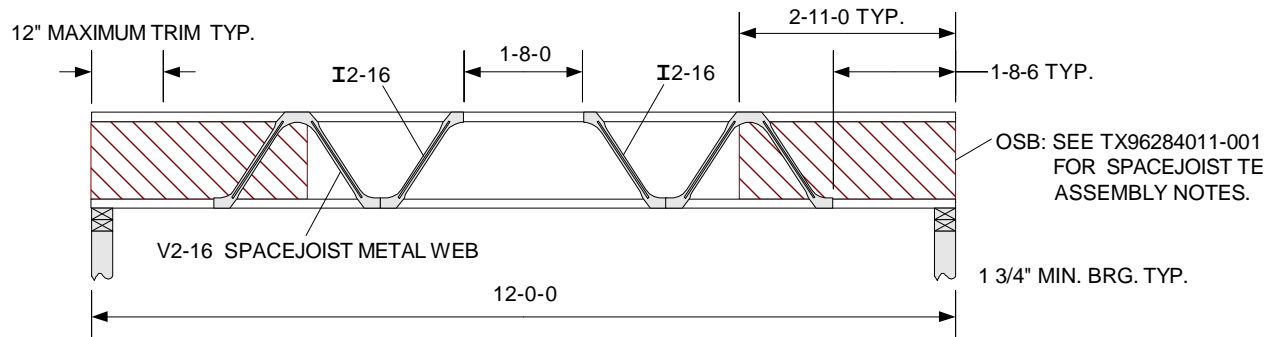

DATE: 02-15-05

ALL WEBS ARE 20 GAUGE SPACEJOIST METAL WEBS MANUFACTURED BY TRUSWAL SYSTEMS CORPORATION.

DESIGNED BY TRUSWAL SYSTEMS



**WARNING** Read all notes on this sheet and give a copy of it to the Erecting Contractor. This design is for an individual building component, not a truss system. It has been based on specifications provided by the component manufacturer and has been completed in accordance with the current versions of TPI and AFPA design standards. No responsibility is assumed for dimensional accuracy. Dimensions are to be verified by the component manufacturer and/or building designer prior to fabrication. The building designer shall ascertain that the loads utilized on this design meet or exceed the loading imposed by the local building code and the particular application. This design assumes that the top chord is laterally braced by the roof or floor sheathing and that the bottom chord is laterally braced by a rigid sheathing material directly attached, unless otherwise noted. Bracing shown is for lateral support of individual component members only. This component shall not be placed in any environment that will cause the moisture content of the wood to exceed 19% and/or cause connector plate corrosion. Fabricate, handle, install, and brace this truss in accordance with the following standards: SPACEJOIST TRUSS FABRICATION MANUAL, by Truswal Systems; Handling, Installing, and Bracing Metal Plate Connected Wood Trusses (HIB-91 and HIB-91 Summary Sheet) by TPI. The Truss Plate Institute is located at 583 D'Onofrio Dr., Ste. 200, Madison, WI 53719. The American Forest and Paper Association (AFPA) is located at 1111 19th St. N.W., Ste. 800, Washington, DC 20036.

Chk:		Customer Name:	SpaceJoist TE
Dsgnr: DL			
TC Live	40 psf	DurFacs: L= 1.00 P= 1.00	
TC Dead	See Span Table	Rep Mbr Bnd: 1.15	
BC Live	0 psf	Spacing: See Span Table	
BC Dead	5 psf	Design Spec: TPI	
TOTAL	See Span Table		

TOP CHORD 4X2 SPF CAN. 2100F-1.8E  
 BOTTOM CHORD 4X2 SPF CAN. 2100F-1.8E  
 LUMBER SHEAR ALLOWABLES ARE PER NDS-1997

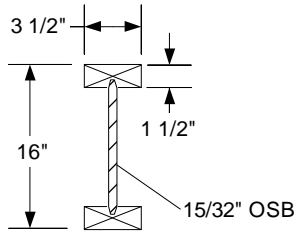

END DETAIL TYP.

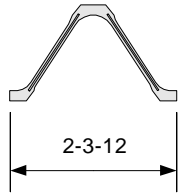

**THIS TRUSS IS TRIMMABLE**  
 UP TO 12" MAY BE FIELD TRIMMED  
 FROM EACH END OF THIS TRUSS

SEE TX96284011-001 FOR SPACEJOIST TE  
 ASSEMBLY AND GENERAL NOTES

16" SPACEJOIST TE MAXIMUM SPANS					
LOADING, PSF	DEFLECTION RATIO	SPACING			
		24" o.c.	19.2" o.c.	16" o.c.	12" o.c.
40-10-5	L/480	22'-0"	26'-0"	28'-6"	30'-0"
	L/360	22'-0"	26'-0"	30'-0"	30'-0"
40-20-5	L/480	18'-3"	22'-0"	26'-0"	30'-0"
	L/360	18'-3"	22'-0"	26'-0"	30'-0"

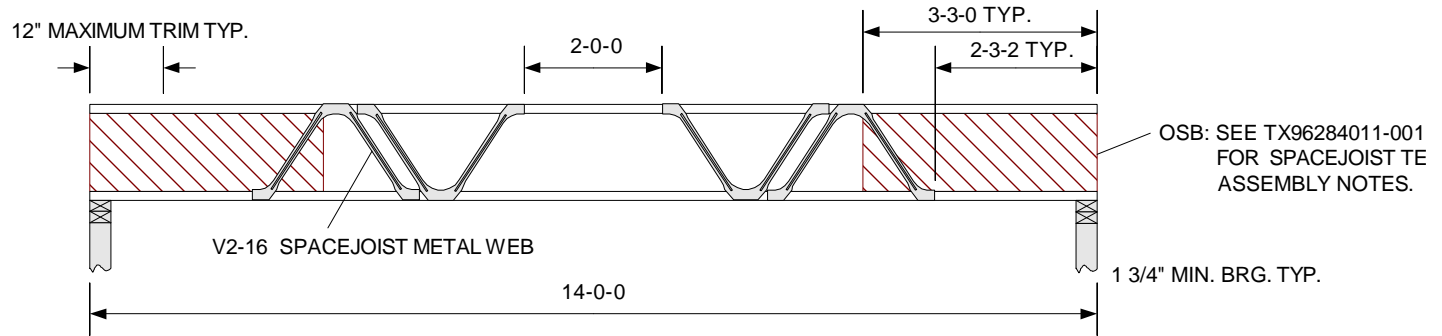

OSB: SEE TX96284011-001 FOR SPACEJOIST TE ASSEMBLY NOTES.

V2-16 SPACEJOIST METAL WEB

1 3/4" MIN. BRG. TYP.

DATE: 02-15-05

DESIGNED BY TRUSWAL SYSTEMS

ALL WEBS ARE 20 GAUGE SPACEJOIST METAL WEBS MANUFACTURED BY TRUSWAL SYSTEMS CORPORATION.



**WARNING** Read all notes on this sheet and give a copy of it to the Erecting Contractor.

This design is for an individual building component, not a truss system. It has been based on specifications provided by the component manufacturer and has been completed in accordance with the current versions of TPI and AFPA design standards. No responsibility is assumed for dimensional accuracy. Dimensions are to be verified by the component manufacturer and/or building designer prior to fabrication. The building designer shall ascertain that the loads utilized on this design meet or exceed the loading imposed by the local building code and the particular application. This design assumes that the top chord is laterally braced by the roof or floor sheathing and that the bottom chord is laterally braced by a rigid sheathing material directly attached, unless otherwise noted. Bracing shown is for lateral support of individual component members only. This component shall not be placed in any environment that will cause the moisture content of the wood to exceed 19% and/or cause connector plate corrosion. Fabricate, handle, install, and brace this truss in accordance with the following standards: *SPACEJOIST TRUSS FABRICATION MANUAL*, by Truswal Systems; *Handling, Installing, and Bracing Metal Plate Connected Wood Trusses* (HIB-91 and HIB-91 Summary Sheet) by TPI. The Truss Plate Institute is located at 583 D'Onofrio Dr., Ste. 200, Madison, WI 53719. The American Forest and Paper Association (AFPA) is located at 1111 19th St. N.W., Ste. 800, Washington, DC 20036.

Chk:  
 Dsgnr: DL

Customer Name:  
**SpaceJoist TE**

TC Live 40 psf  
 TC Dead See Span Table  
 BC Live 0 psf  
 BC Dead 5 psf  
 TOTAL See Span Table

DurFacs: L= 1.00 P= 1.00  
 Rep Mbr Bnd: 1.15  
 Spacing: See Span Table  
 Design Spec: TPI

TOP CHORD 4X2 SPF CAN. 2100F-1.8E  
 BOTTOM CHORD 4X2 SPF CAN. 2100F-1.8E  
 LUMBER SHEAR ALLOWABLES ARE PER NDS-1997

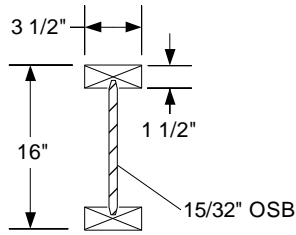

END DETAIL TYP.

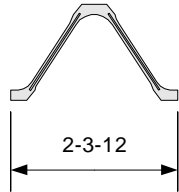

16" SPACEJOIST TE MAXIMUM SPANS					
LOADING, PSF	DEFLECTION RATIO	SPACING			
		24" o.c.	19.2" o.c.	16" o.c.	12" o.c.
40-10-5	L/480	22'-0"	26'-0"	28'-6"	30'-0"
	L/360	22'-0"	26'-0"	30'-0"	30'-0"
40-20-5	L/480	18'-3"	22'-0"	26'-0"	30'-0"
	L/360	18'-3"	22'-0"	26'-0"	30'-0"

**THIS TRUSS IS TRIMMABLE**

UP TO 12" MAY BE FIELD TRIMMED FROM EACH END OF THIS TRUSS

SEE TX96284011-001 FOR SPACEJOIST TE ASSEMBLY AND GENERAL NOTES

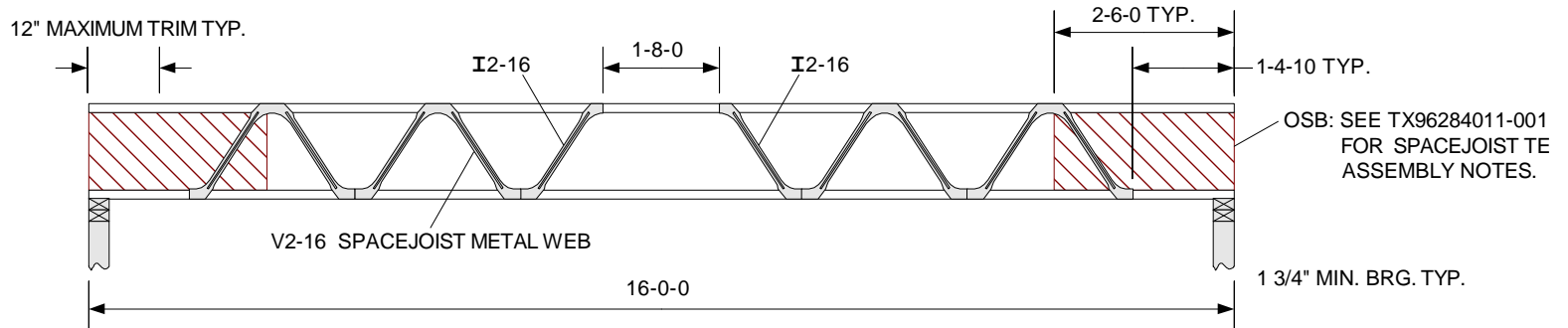

DATE: 02-15-05

ALL WEBS ARE 20 GAUGE SPACEJOIST METAL WEBS MANUFACTURED BY TRUSWAL SYSTEMS CORPORATION.

DESIGNED BY TRUSWAL SYSTEMS



**WARNING** Read all notes on this sheet and give a copy of it to the Erecting Contractor. This design is for an individual building component, not a truss system. It has been based on specifications provided by the component manufacturer and has been completed in accordance with the current versions of TPI and AFPA design standards. No responsibility is assumed for dimensional accuracy. Dimensions are to be verified by the component manufacturer and/or building designer prior to fabrication. The building designer shall ascertain that the loads utilized on this design meet or exceed the loading imposed by the local building code and the particular application. This design assumes that the top chord is laterally braced by the roof or floor sheathing and that the bottom chord is laterally braced by a rigid sheathing material directly attached, unless otherwise noted. Bracing shown is for lateral support of individual component members only. This component shall not be placed in any environment that will cause the moisture content of the wood to exceed 19% and/or cause connector plate corrosion. Fabricate, handle, install, and brace this truss in accordance with the following standards: SPACEJOIST TRUSS FABRICATION MANUAL, by Truswal Systems; Handling, Installing, and Bracing Metal Plate Connected Wood Trusses (HIB-91 and HIB-91 Summary Sheet) by TPI. The Truss Plate Institute is located at 583 D'Onofrio Dr., Ste. 200, Madison, WI 53719. The American Forest and Paper Association (AFPA) is located at 1111 19th St. N.W., Ste. 800, Washington, DC 20036.

Chk:		Customer Name:	SpaceJoist TE
Dsgnr:	DL		
TC Live	40 psf	DurFacs:	L= 1.00 P= 1.00
TC Dead	See Span Table	Rep Mbr Bnd:	1.15
BC Live	0 psf	Spacing:	See Span Table
BC Dead	5 psf	Design Spec:	TPI
TOTAL	See Span Table		

TOP CHORD 4X2 SPF CAN. 2100F-1.8E  
 BOTTOM CHORD 4X2 SPF CAN. 2100F-1.8E  
 LUMBER SHEAR ALLOWABLES ARE PER NDS-1997

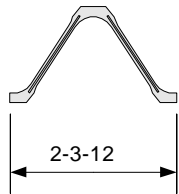
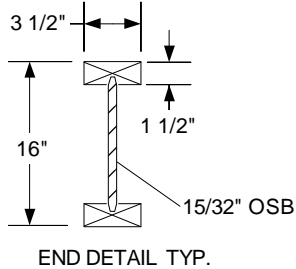

**THIS TRUSS IS TRIMMABLE**

UP TO 12" MAY BE FIELD TRIMMED FROM EACH END OF THIS TRUSS

SEE TX96284011-001 FOR SPACEJOIST TE ASSEMBLY AND GENERAL NOTES

16" SPACEJOIST TE MAXIMUM SPANS					
LOADING, PSF	DEFLECTION RATIO	SPACING			
		24" o.c.	19.2" o.c.	16" o.c.	12" o.c.
40-10-5	L/480	22'-0"	26'-0"	28'-6"	30'-0"
	L/360	22'-0"	26'-0"	30'-0"	30'-0"
40-20-5	L/480	18'-3"	22'-0"	26'-0"	30'-0"
	L/360	18'-3"	22'-0"	26'-0"	30'-0"

12" MAXIMUM TRIM TYP.

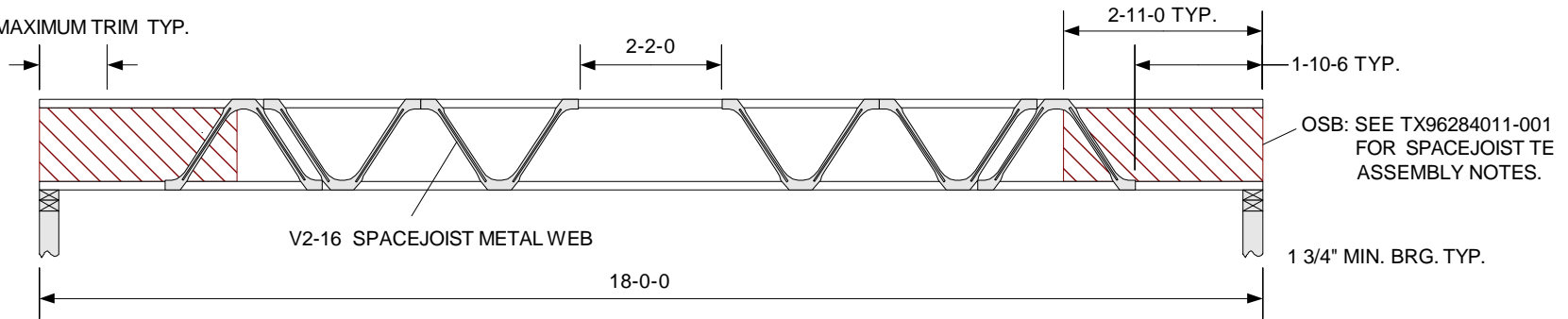

DATE: 02-15-05

ALL WEBS ARE 20 GAUGE SPACEJOIST METAL WEBS MANUFACTURED BY TRUSWAL SYSTEMS CORPORATION.

DESIGNED BY TRUSWAL SYSTEMS



**WARNING** Read all notes on this sheet and give a copy of it to the Erecting Contractor. This design is for an individual building component, not a truss system. It has been based on specifications provided by the component manufacturer and has been completed in accordance with the current versions of TPI and AFPA design standards. No responsibility is assumed for dimensional accuracy. Dimensions are to be verified by the component manufacturer and/or building designer prior to fabrication. The building designer shall ascertain that the loads utilized on this design meet or exceed the loading imposed by the local building code and the particular application. This design assumes that the top chord is laterally braced by the roof or floor sheathing and that the bottom chord is laterally braced by a rigid sheathing material directly attached, unless otherwise noted. Bracing shown is for lateral support of individual component members only. This component shall not be placed in any environment that will cause the moisture content of the wood to exceed 19% and/or cause connector plate corrosion. Fabricate, handle, install, and brace this truss in accordance with the following standards: SPACEJOIST TRUSS FABRICATION MANUAL, by Truswal Systems; Handling, Installing, and Bracing Metal Plate Connected Wood Trusses (HIB-91 and HIB-91 Summary Sheet) by TPI. The Truss Plate Institute is located at 583 D'Onofrio Dr., Ste. 200, Madison, WI 53719. The American Forest and Paper Association (AFPA) is located at 1111 19th St. N.W., Ste. 800, Washington, DC 20036.

Chk:	
Dsgnr: DL	
TC Live	40 psf
TC Dead	See Span Table
BC Live	0 psf
BC Dead	5 psf
TOTAL	See Span Table

Customer Name:	SpaceJoist TE
DurFacs:	L= 1.00 P= 1.00
Rep Mbr Bnd:	1.15
Spacing:	See Span Table
Design Spec:	TPI

TOP CHORD 4X2 SPF CAN. 2100F-1.8E  
 BOTTOM CHORD 4X2 SPF CAN. 2100F-1.8E  
 LUMBER SHEAR ALLOWABLES ARE PER NDS-1997

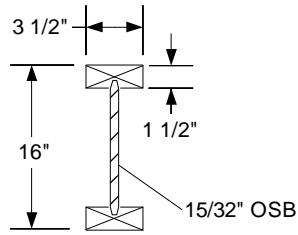

END DETAIL TYP.

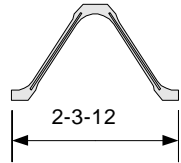

**THIS TRUSS IS TRIMMABLE**  
 UP TO 12" MAY BE FIELD TRIMMED  
 FROM EACH END OF THIS TRUSS  
 SEE TX96284011-001 FOR SPACEJOIST TE  
 ASSEMBLY AND GENERAL NOTES

16" SPACEJOIST TE MAXIMUM SPANS					
LOADING, PSF	DEFLECTION RATIO	SPACING			
		24" o.c.	19.2" o.c.	16" o.c.	12" o.c.
40-10-5	L/480	22'-0"	26'-0"	28'-6"	30'-0"
	L/360	22'-0"	26'-0"	30'-0"	30'-0"
40-20-5	L/480	18'-3"	22'-0"	26'-0"	30'-0"
	L/360	18'-3"	22'-0"	26'-0"	30'-0"

OSB: SEE TX96284011-001 FOR  
 SPACEJOIST TE ASSEMBLY NOTES.

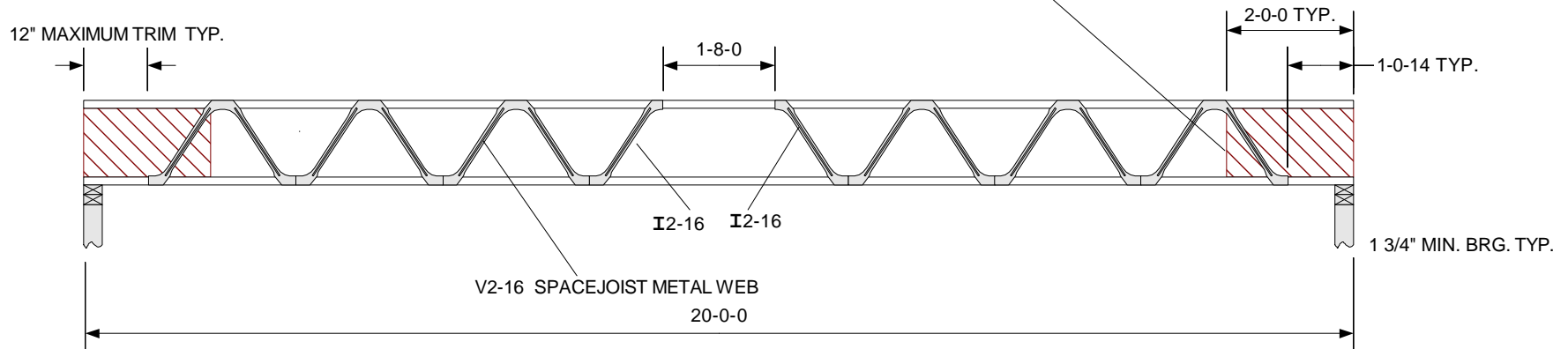

DATE: 02-15-05

ALL WEBS ARE 20 GAUGE SPACEJOIST METAL WEBS MANUFACTURED BY TRUSWAL SYSTEMS CORPORATION.

DESIGNED BY TRUSWAL SYSTEMS



**WARNING** Read all notes on this sheet and give a copy of it to the Erecting Contractor.  
 This design is for an individual building component, not a truss system. It has been based on specifications provided by the component manufacturer and has been completed in accordance with the current versions of TPI and AFPA design standards. No responsibility is assumed for dimensional accuracy. Dimensions are to be verified by the component manufacturer and/or building designer prior to fabrication. The building designer shall ascertain that the loads utilized on this design meet or exceed the loading imposed by the local building code and the particular application. This design assumes that the top chord is laterally braced by the roof or floor sheathing and that the bottom chord is laterally braced by a rigid sheathing material directly attached, unless otherwise noted. Bracing shown is for lateral support of individual component members only. This component shall not be placed in any environment that will cause the moisture content of the wood to exceed 19% and/or cause connector plate corrosion. Fabricate, handle, install, and brace this truss in accordance with the following standards: SPACEJOIST TRUSS FABRICATION MANUAL, by Truswal Systems; Handling, Installing, and Bracing Metal Plate Connected Wood Trusses (HIB-91 and HIB-91 Summary Sheet) by TPI. The Truss Plate Institute is located at 583 D'Onofrio Dr., Ste. 200, Madison, WI 53719. The American Forest and Paper Association (AFPA) is located at 1111 19th St. N.W., Ste. 800, Washington, DC 20036.

Chk:	
Dsgnr: DL	
TC Live	40 psf
TC Dead	See Span Table
BC Live	0 psf
BC Dead	5 psf
TOTAL	See Span Table

Customer Name:	SpaceJoist TE
DurFacs: L=	1.00 P= 1.00
Rep Mbr Bnd:	1.15
Spacing:	See Span Table
Design Spec:	TPI

TOP CHORD 4X2 SPF CAN. 2100F-1.8E  
 BOTTOM CHORD 4X2 SPF CAN. 2100F-1.8E  
 LUMBER SHEAR ALLOWABLES ARE PER NDS-1997

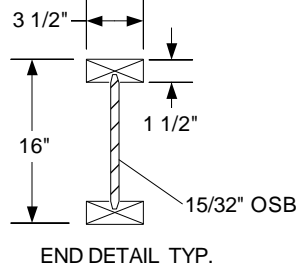

**THIS TRUSS IS TRIMMABLE**  
 UP TO 12" MAY BE FIELD-TRIMMED FROM EACH END OF THIS TRUSS.

SEE TX96284011-001 FOR SPACEJOIST TE ASSEMBLY AND GENERAL NOTES

16" SPACEJOIST TE MAXIMUM SPANS					
LOADING, PSF	DEFLECTION RATIO	SPACING			
		24" o.c.	19.2" o.c.	16" o.c.	12" o.c.
40-10-5	L/480	22'-0"	26'-0"	28'-6"	30'-0"
	L/360	22'-0"	26'-0"	30'-0"	30'-0"
40-20-5	L/480	18'-3"	22'-0"	26'-0"	30'-0"
	L/360	18'-3"	22'-0"	26'-0"	30'-0"

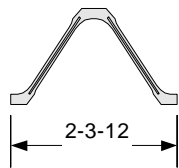

OSB: SEE TX96284011-001 FOR SPACEJOIST TE ASSEMBLY NOTES.

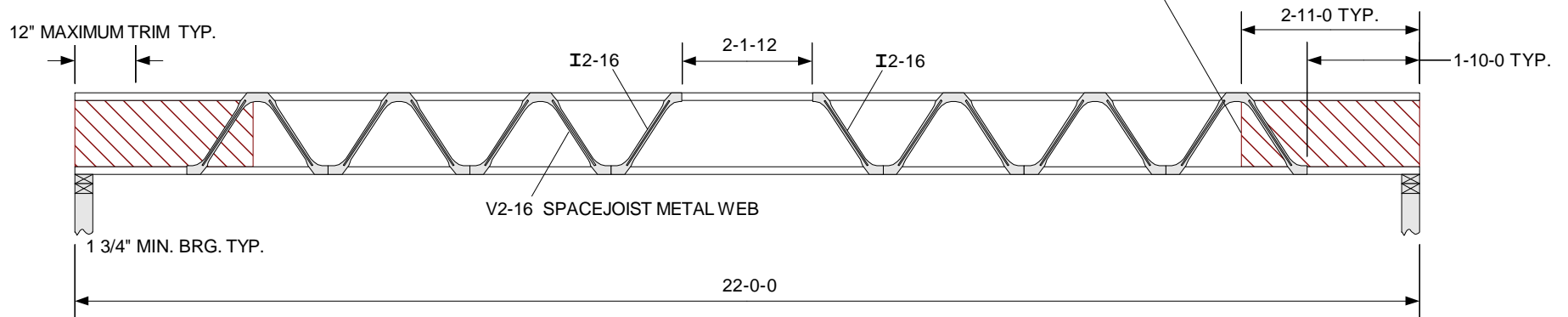

ALL WEBS ARE 20 GAUGE SPACEJOIST METAL WEBS MANUFACTURED BY TRUSWAL SYSTEMS CORPORATION.

DATE: 02-15-05  
 DESIGNED BY TRUSWAL SYSTEMS



**WARNING** Read all notes on this sheet and give a copy of it to the Erecting Contractor.  
 This design is for an individual building component, not a truss system. It has been based on specifications provided by the component manufacturer and has been completed in accordance with the current versions of TPI and AFPA design standards. No responsibility is assumed for dimensional accuracy. Dimensions are to be verified by the component manufacturer and/or building designer prior to fabrication. The building designer shall ascertain that the loads utilized on this design meet or exceed the loading imposed by the local building code and the particular application. This design assumes that the top chord is laterally braced by the roof or floor sheathing and that the bottom chord is laterally braced by a rigid sheathing material directly attached, unless otherwise noted. Bracing shown is for lateral support of individual component members only. This component shall not be placed in any environment that will cause the moisture content of the wood to exceed 19% and/or cause connector plate corrosion. Fabricate, handle, install, and brace this truss in accordance with the following standards: SPACEJOIST TRUSS FABRICATION MANUAL, by Truswal Systems; Handling, Installing, and Bracing Metal Plate Connected Wood Trusses (HIB-91 and HIB-91 Summary Sheet) by TPI. The Truss Plate Institute is located at 583 D'Onofrio Dr., Ste. 200, Madison, WI 53719. The American Forest and Paper Association (AFPA) is located at 1111 19th St. N.W., Ste. 800, Washington, DC 20036.

Chk: Dsgnr: DL	Customer Name: <b>SpaceJoist TE</b>
TC Live 40 psf TC Dead See Span Table BC Live 0 psf BC Dead 5 psf TOTAL See Span Table	DurFacs: L= 1.00 P= 1.00 Rep Mbr Bnd: 1.15 Spacing: See Span Table Design Spec: TPI

TOP CHORD 4X2 SPF CAN. 2100F-1.8E  
 BOTTOM CHORD 4X2 SPF CAN. 2100F-1.8E  
 LUMBER SHEAR ALLOWABLES ARE PER NDS-1997

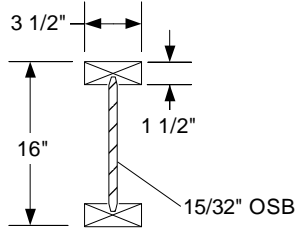

END DETAIL TYP.

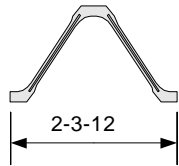

**THIS TRUSS IS TRIMMABLE**  
 UP TO 12" MAY BE FIELD TRIMMED  
 FROM EACH END OF THIS TRUSS

SEE TX96284011-001 FOR SPACEJOIST TE  
 ASSEMBLY AND GENERAL NOTES

16" SPACEJOIST TE MAXIMUM SPANS					
LOADING, PSF	DEFLECTION RATIO	SPACING			
		24" o.c.	19.2" o.c.	16" o.c.	12" o.c.
40-10-5	L/480	22'-0"	26'-0"	28'-6"	30'-0"
	L/360	22'-0"	26'-0"	30'-0"	30'-0"
40-20-5	L/480	18'-3"	22'-0"	26'-0"	30'-0"
	L/360	18'-3"	22'-0"	26'-0"	30'-0"

OSB: SEE TX96284011-001 FOR  
 SPACEJOIST TE ASSEMBLY NOTES.

12" MAXIMUM TRIM TYP.

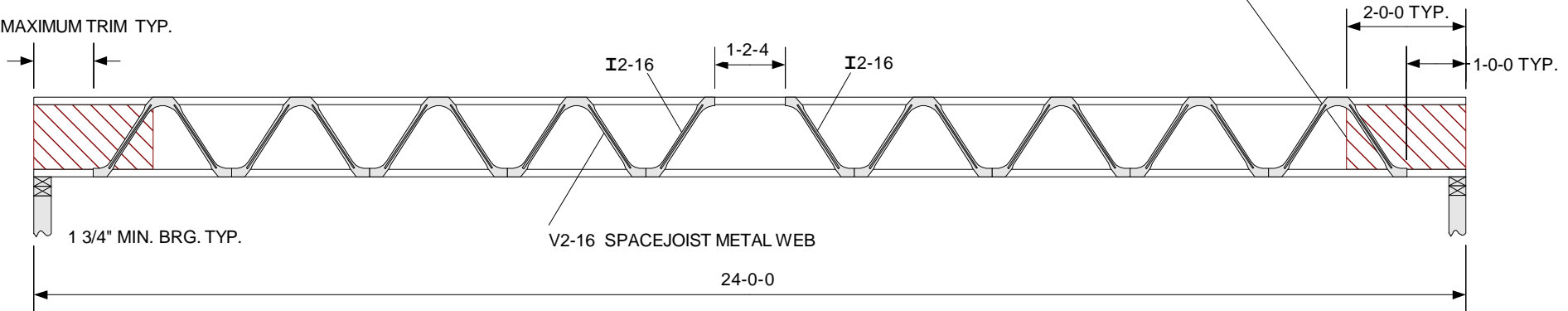

ALL WEBS ARE 20 GAUGE SPACEJOIST METAL WEBS MANUFACTURED BY TRUSWAL SYSTEMS CORPORATION.

DATE: 02-15-05  
 DESIGNED BY TRUSWAL SYSTEMS



**WARNING** Read all notes on this sheet and give a copy of it to the Erecting Contractor.  
 This design is for an individual building component, not a truss system. It has been based on specifications provided by the component manufacturer and has been completed in accordance with the current versions of TPI and AFPA design standards. No responsibility is assumed for dimensional accuracy. Dimensions are to be verified by the component manufacturer and/or building designer prior to fabrication. The building designer shall ascertain that the loads utilized on this design meet or exceed the loading imposed by the local building code and the particular application. This design assumes that the top chord is laterally braced by the roof or floor sheathing and that the bottom chord is laterally braced by a rigid sheathing material directly attached, unless otherwise noted. Bracing shown is for lateral support of individual component members only. This component shall not be placed in any environment that will cause the moisture content of the wood to exceed 19% and/or cause connector plate corrosion. Fabricate, handle, install, and brace this truss in accordance with the following standards: SPACEJOIST TRUSS FABRICATION MANUAL, by Truswal Systems; Handling, Installing, and Bracing Metal Plate Connected Wood Trusses (HIB-91 and HIB-91 Summary Sheet) by TPI. The Truss Plate Institute is located at 583 D'Onofrio Dr., Ste. 200, Madison, WI 53719. The American Forest and Paper Association (AFPA) is located at 1111 19th St. N.W., Ste. 800, Washington, DC 20036.

Chk:	
Dsgnr: DL	
TC Live	40 psf
TC Dead	See Span Table
BC Live	0 psf
BC Dead	5 psf
TOTAL	See Span Table

Customer Name:	SpaceJoist TE
DurFacs:	L= 1.00 P= 1.00
Rep Mbr Bnd:	1.15
Spacing:	See Span Table
Design Spec:	TPI

TOP CHORD 4X2 SPF CAN. 2100F-1.8E  
 BOTTOM CHORD 4X2 SPF CAN. 2100F-1.8E  
 LUMBER SHEAR ALLOWABLES ARE PER NDS-1997

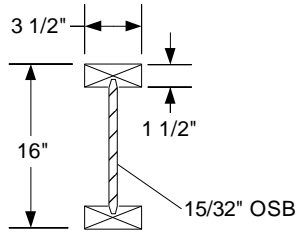

END DETAIL TYP.

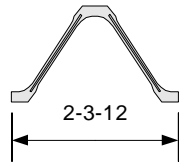

**THIS TRUSS IS TRIMMABLE**  
 UP TO 12" MAY BE FIELD TRIMMED  
 FROM EACH END OF THIS TRUSS

SEE TX96284011-001 FOR SPACEJOIST TE  
 ASSEMBLY AND GENERAL NOTES

16" SPACEJOIST TE MAXIMUM SPANS					
LOADING, PSF	DEFLECTION RATIO	SPACING			
		24" o.c.	19.2" o.c.	16" o.c.	12" o.c.
40-10-5	L/480	22'-0"	26'-0"	28'-6"	30'-0"
	L/360	22'-0"	26'-0"	30'-0"	30'-0"
40-20-5	L/480	18'-3"	22'-0"	26'-0"	30'-0"
	L/360	18'-3"	22'-0"	26'-0"	30'-0"

OSB: SEE TX96284011-001 FOR  
 SPACEJOIST TE ASSEMBLY NOTES.

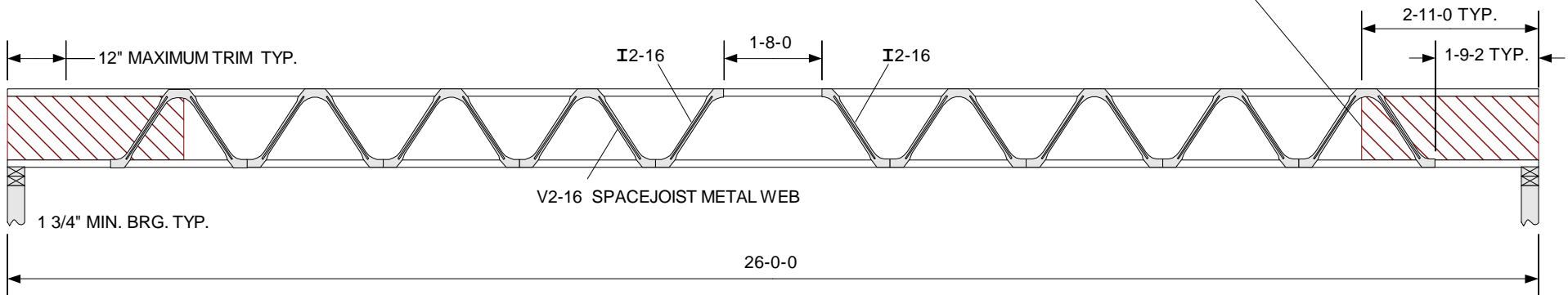

ALL WEBS ARE 20 GAUGE SPACEJOIST METAL WEBS MANUFACTURED BY TRUSWAL SYSTEMS CORPORATION.

DATE: 02-15-05  
 DESIGNED BY TRUSWAL SYSTEMS



**WARNING** Read all notes on this sheet and give a copy of it to the Erecting Contractor.  
 This design is for an individual building component, not a truss system. It has been based on specifications provided by the component manufacturer and has been completed in accordance with the current versions of TPI and AFPA design standards. No responsibility is assumed for dimensional accuracy. Dimensions are to be verified by the component manufacturer and/or building designer prior to fabrication. The building designer shall ascertain that the loads utilized on this design meet or exceed the loading imposed by the local building code and the particular application. This design assumes that the top chord is laterally braced by the roof or floor sheathing and that the bottom chord is laterally braced by a rigid sheathing material directly attached, unless otherwise noted. Bracing shown is for lateral support of individual component members only. This component shall not be placed in any environment that will cause the moisture content of the wood to exceed 19% and/or cause connector plate corrosion. Fabricate, handle, install, and brace this truss in accordance with the following standards: SPACEJOIST TRUSS FABRICATION MANUAL, by Truswal Systems; Handling, Installing, and Bracing Metal Plate Connected Wood Trusses (HIB-91 and HIB-91 Summary Sheet) by TPI. The Truss Plate Institute is located at 583 D'Onofrio Dr., Ste. 200, Madison, WI 53719. The American Forest and Paper Association (AFPA) is located at 1111 19th St. N.W., Ste. 800, Washington, DC 20036.

Chk:		Customer Name:	Spacejoist TE
Dsgnr:	DL		
TC Live	40 psf	DurFacs:	L= 1.00 P= 1.00
TC Dead	See Span Table	Rep Mbr Bnd:	1.15
BC Live	0 psf	Spacing:	See Span Table
BC Dead	5 psf	Design Spec:	TPI
TOTAL	See Span Table		

TOP CHORD 4X2 SPF CAN. 2100F-1.8E  
 BOTTOM CHORD 4X2 SPF CAN. 2100F-1.8E  
 LUMBER SHEAR ALLOWABLES ARE PER NDS-1997

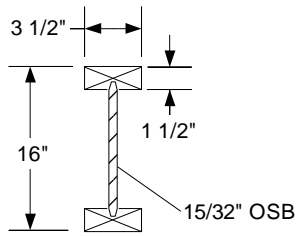

END DETAIL TYP.

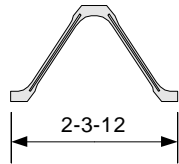

**THIS TRUSS IS TRIMMABLE**  
 UP TO 12" MAY BE FIELD TRIMMED  
 FROM EACH END OF THIS TRUSS

SEE TX96284011-001 FOR SPACEJOIST TE  
 ASSEMBLY AND GENERAL NOTES

16" SPACEJOIST TE MAXIMUM SPANS					
LOADING, PSF	DEFLECTION RATIO	SPACING			
		24" o.c.	19.2" o.c.	16" o.c.	12" o.c.
40-10-5	L/480	22'-0"	26'-0"	28'-6"	30'-0"
	L/360	22'-0"	26'-0"	30'-0"	30'-0"
40-20-5	L/480	18'-3"	22'-0"	26'-0"	30'-0"
	L/360	18'-3"	22'-0"	26'-0"	30'-0"

OSB: SEE TX96284011-001 FOR  
 SPACEJOIST TE ASSEMBLY NOTES.

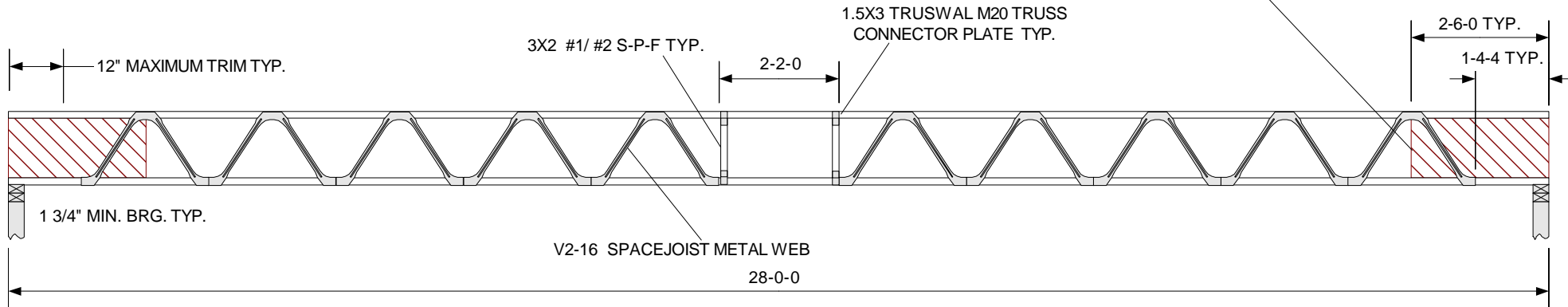

DATE: 02-15-05

ALL WEBS ARE 20 GAUGE SPACEJOIST METAL WEBS MANUFACTURED BY TRUSWAL SYSTEMS CORPORATION.

DESIGNED BY TRUSWAL SYSTEMS



**WARNING** Read all notes on this sheet and give a copy of it to the Erecting Contractor.  
 This design is for an individual building component, not a truss system. It has been based on specifications provided by the component manufacturer and has been completed in accordance with the current versions of TPI and AFPA design standards. No responsibility is assumed for dimensional accuracy. Dimensions are to be verified by the component manufacturer and/or building designer prior to fabrication. The building designer shall ascertain that the loads utilized on this design meet or exceed the loading imposed by the local building code and the particular application. This design assumes that the top chord is laterally braced by the roof or floor sheathing and that the bottom chord is laterally braced by a rigid sheathing material directly attached, unless otherwise noted. Bracing shown is for lateral support of individual component members only. This component shall not be placed in any environment that will cause the moisture content of the wood to exceed 19% and/or cause connector plate corrosion. Fabricate, handle, install, and brace this truss in accordance with the following standards: SPACEJOIST TRUSS FABRICATION MANUAL, by Truswal Systems; Handling, Installing, and Bracing Metal Plate Connected Wood Trusses (HIB-91 and HIB-91 Summary Sheet) by TPI. The Truss Plate Institute is located at 583 D'Onofrio Dr., Ste. 200, Madison, WI 53719. The American Forest and Paper Association (AFPA) is located at 1111 19th St. N.W., Ste. 800, Washington, DC 20036.

Chk: Dsgnr: DL	Customer Name: <b>SpaceJoist TE</b>
TC Live 40 psf TC Dead See Span Table BC Live 0 psf BC Dead 5 psf TOTAL See Span Table	DurFacs: L= 1.00 P= 1.00 Rep Mbr Bnd: 1.15 Spacing: See Span Table Design Spec: TPI

TOP CHORD 4X2 SPF CAN. 2100F-1.8E  
 BOTTOM CHORD 4X2 SPF CAN. 2100F-1.8E  
 LUMBER SHEAR ALLOWABLES ARE PER NDS-1997

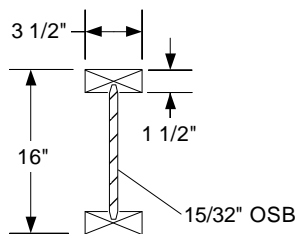

END DETAIL TYP.

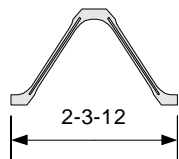

**THIS TRUSS IS TRIMMABLE**

UP TO 12" MAY BE FIELD TRIMMED FROM EACH END OF THIS TRUSS

SEE TX96284011-001 FOR SPACEJOIST TE ASSEMBLY AND GENERAL NOTES

16" SPACEJOIST TE MAXIMUM SPANS					
LOADING, PSF	DEFLECTION RATIO	SPACING			
		24" o.c.	19.2" o.c.	16" o.c.	12" o.c.
40-10-5	L/480	22'-0"	26'-0"	28'-6"	30'-0"
	L/360	22'-0"	26'-0"	30'-0"	30'-0"
40-20-5	L/480	18'-3"	22'-0"	26'-0"	30'-0"
	L/360	18'-3"	22'-0"	26'-0"	30'-0"

OSB: SEE TX96284011-001 FOR SPACEJOIST TE ASSEMBLY NOTES.

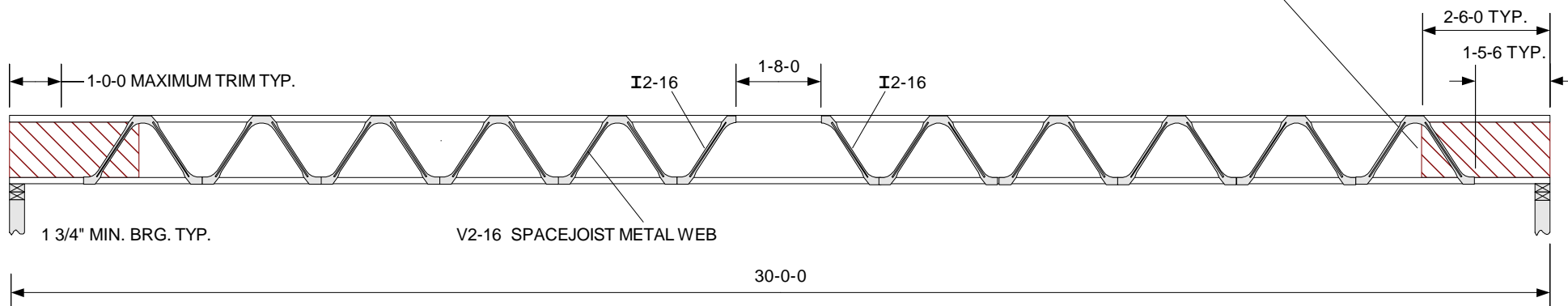

ALL WEBS ARE 20 GAUGE SPACEJOIST METAL WEBS MANUFACTURED BY TRUSWAL SYSTEMS CORPORATION.

DATE: 02-15-05

DESIGNED BY TRUSWAL SYSTEMS



**WARNING** Read all notes on this sheet and give a copy of it to the Erecting Contractor. This design is for an individual building component, not a truss system. It has been based on specifications provided by the component manufacturer and has been completed in accordance with the current versions of TPI and AFPA design standards. No responsibility is assumed for dimensional accuracy. Dimensions are to be verified by the component manufacturer and/or building designer prior to fabrication. The building designer shall ascertain that the loads utilized on this design meet or exceed the loading imposed by the local building code and the particular application. This design assumes that the top chord is laterally braced by the roof or floor sheathing and that the bottom chord is laterally braced by a rigid sheathing material directly attached, unless otherwise noted. Bracing shown is for lateral support of individual component members only. This component shall not be placed in any environment that will cause the moisture content of the wood to exceed 19% and/or cause connector plate corrosion. Fabricate, handle, install, and brace this truss in accordance with the following standards: SPACEJOIST TRUSS FABRICATION MANUAL, by Truswal Systems; Handling, Installing, and Bracing Metal Plate Connected Wood Trusses (HIB-91 and HIB-91 Summary Sheet) by TPI. The Truss Plate Institute is located at 583 D'Onofrio Dr., Ste. 200, Madison, WI 53719. The American Forest and Paper Association (AFPA) is located at 1111 19th St. N.W., Ste. 800, Washington, DC 20036.

Chk:		Customer Name:	SpaceJoist TE
Dsgnr: DL		DurFacs: L= 1.00 P= 1.00	
TC Live	40 psf	Rep Mbr Bnd: 1.15	
TC Dead	See Span Table	Spacing: See Span Table	
BC Live	0 psf	Design Spec: TPI	
BC Dead	5 psf		
TOTAL	See Span Table		